

# **Hawaii PMMIS**

## Hawaii Prepaid Medical Management Information System

### ***Technical Guide***

### ***Provider***

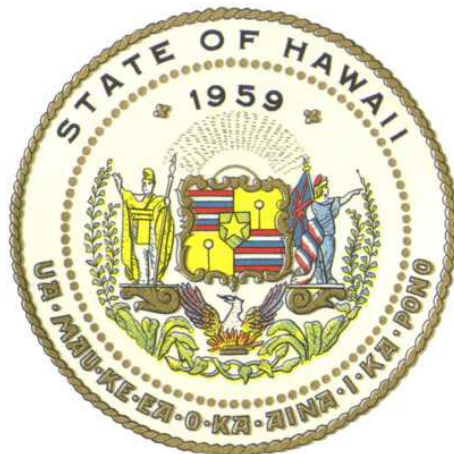

**Version 3.3**  
**April 2024**

## Table of Contents

1	Preface.....	8
1.1	Overview .....	8
1.2	Provider Registration and Affiliation .....	8
1.3	Conventions Used in this Manual.....	9
2	Provider Interface.....	10
2.1	Health Plan Provider Network .....	10
2.1.1	Provider Registry Definitions.....	10
2.2	Preparing Provider Data for Health Plan Submission (HPS) File .....	11
2.2.1	Provider Submission Cycle .....	12
2.2.2	General Guidelines .....	12
2.2.2.1	Required Data Elements .....	12
2.2.2.2	Field Values .....	12
2.2.3	Master Record (AA) .....	13
2.2.4	Address Record (BB).....	13
2.2.5	Group Record (CC).....	13
2.2.6	Specialty Record (DD) .....	13
2.2.7	EPSDT Record (EE) .....	14
2.2.8	License Record (FF) .....	14
2.2.9	Contract Dates Record (GG) .....	15
2.2.10	CLIA Record (HH).....	15
2.2.11	Reimbursement Type Record (II).....	15
2.2.12	Enrollment Record (JJ) .....	15
2.2.13	NPI Record (KK) .....	15
2.2.14	Membership Record (LL) .....	16
2.2.15	Provider Credentialing Record (MM) .....	16
2.2.16	Ownership-Personnel Record (NN) .....	16
2.2.17	Category of Service (OO) .....	16
2.3	Processing Provider Network Submissions.....	16
2.4	Provider Master Registry (PMR) .....	17
2.5	File Transfer and Retention.....	17
2.6	Provider File Testing .....	18
3	Appendices .....	18
3.1	Appendix 3A – Provider Master Registry / Health Plan Provider Network.....	18
3.1.1	File Header Record Format .....	18
3.1.2	AA Master Record.....	18
3.1.3	BB – Address Record .....	19
3.1.4	CC – Group Record .....	20
3.1.5	DD – Specialty Record.....	21
3.1.6	EE – EPSDT Record.....	21

**Hawaii PMMIS**  
**Hawaii Prepaid Medical Management Information System**  
**Technical Guide - Provider**

3.1.7	FF – License Type Record.....	22
3.1.8	GG – Contract Record .....	22
3.1.9	HH – CLIA Record .....	23
3.1.10	II – Reimbursement Type (PMR File Only).....	23
3.1.11	JJ – Enrollment Record (PMR File Only).....	25
3.1.12	KK – NPI Record (PMR File Only).....	25
3.1.13	LL – Membership Record (Health Plan Submission file only) .....	26
3.1.14	MM – Credentialing Record (PMR File Only) .....	26
3.1.15	NN - Ownership-Personnel Record (PMR File Only).....	27
3.1.16	OO – Category of Service Record (PMR File Only) .....	28
3.1.17	File Trailer Record Format.....	29
<b>3.2</b>	<b>Appendix 3B – Provider Codes and Values .....</b>	<b>29</b>
3.2.1	Agency Codes.....	29
3.2.2	License Type Codes .....	30
3.2.3	Provider Status Codes (PMR Only) .....	32
3.2.4	Provider Type Codes .....	34
3.2.5	Provider Specialty Codes.....	36
3.2.6	Reimbursement Types.....	40
3.2.7	Provider Types Requiring Ownership/Personnel Data .....	40
3.2.8	Title Codes – In Hierarchy Order (for NN record only) .....	41
3.2.9	Criminal Offense Codes (for NN record only).....	41
3.2.10	Language Codes.....	42
<b>3.3</b>	<b>Appendix 3C – Provider Error Report.....</b>	<b>45</b>
3.3.1	File Header Record Format (Provider Error Report).....	45
3.3.2	Provider Detail Error Report Record Format .....	45
3.3.3	File Trailer Record Format (Provider Error Report) .....	46
<b>3.4</b>	<b>Appendix 3D – Provider Health Plan Submission (HPS) and Provider Master Registry (PMR) Record Index/Data Elements .....</b>	<b>46</b>
3.4.1	Record Type.....	46
3.4.2	Health Plan ID .....	47
3.4.3	Health Plan Provider ID .....	48
3.4.4	QUEST Provider ID.....	48
3.4.5	Name.....	48
3.4.6	SSN.....	49
3.4.7	Provider Type.....	49
3.4.8	Provider Status.....	49
3.4.9	NPI .....	50
3.4.10	NPI Begin Date .....	50
3.4.11	Date of Birth .....	50
3.4.12	Gender .....	51
3.4.13	Language Code 1 .....	51
3.4.14	Language Code 2 .....	51
3.4.15	Language Code 3 .....	52
3.4.16	Language Code 4 .....	52
3.4.17	Location Code .....	52
3.4.18	Address Type.....	53

**Hawaii PMMIS**  
**Hawaii Prepaid Medical Management Information System**  
**Technical Guide - Provider**

3.4.19	FEIN .....	53
3.4.20	Mail Indicator .....	53
3.4.21	Street Address #1 .....	54
3.4.22	Street Address #2 .....	54
3.4.23	City .....	54
3.4.24	State .....	55
3.4.25	Zip Code .....	55
3.4.26	Address Begin Date .....	56
3.4.27	Address End Date .....	56
3.4.28	Health Plan Group ID .....	56
3.4.29	Group QUEST ID .....	57
3.4.30	Group Begin Date .....	57
3.4.31	Group End Date .....	57
3.4.32	Primary Indicator .....	58
3.4.33	Specialty Code .....	58
3.4.34	Specialty Begin Date .....	58
3.4.35	Specialty End Date .....	59
3.4.36	PCP Indicator .....	59
3.4.37	PCP Specialty Indicator (PMR File Only) .....	59
3.4.38	Attestation Date (PMR File Only) .....	60
3.4.39	EPSDT Begin Date .....	60
3.4.40	EPSDT End Date .....	60
3.4.41	Agency ID .....	61
3.4.42	DEA Level .....	61
3.4.43	License/Certificate Number .....	61
3.4.44	License/Certification Begin Date .....	62
3.4.45	License/Certification Expiration Date .....	62
3.4.46	Contract Begin Date .....	62
3.4.47	Contract End Date .....	63
3.4.48	CLIA Number .....	63
3.4.49	Street Address #1 .....	63
3.4.50	Street Address #2 .....	64
3.4.51	City .....	64
3.4.52	State .....	64
3.4.53	Zip Code .....	65
3.4.54	CLIA Begin Date .....	65
3.4.55	CLIA End Date .....	66
3.4.56	Attention To (PMR file only) .....	66
3.4.57	Address Phone (PMR file only) .....	66
3.4.58	Address Fax (PMR file only) .....	66
3.4.59	Reimbursement Type (PMR file only) .....	67
3.4.60	Reimbursement Begin Date (PMR file only) .....	67
3.4.61	Reimbursement End Date (PMR file only) .....	67
3.4.62	Provider Status Type (PMR file only) .....	68
3.4.63	Provider Status Code (PMR file only) .....	68
3.4.64	Provider Status Begin Date (PMR file only) .....	68
3.4.65	Provider Status End Date (PMR file only) .....	68
3.4.66	Replacement Provider ID (PMR file only) .....	69

**Hawaii PMMIS**  
**Hawaii Prepaid Medical Management Information System**  
**Technical Guide - Provider**

3.4.67	NPI (PMR file only) .....	69
3.4.68	NPI Begin Date (PMR file only).....	69
3.4.69	NPI End Date (PMR file only) .....	69
3.4.70	Island Code (HPS file only).....	70
3.4.71	Recipient Count (HPS file only) .....	70
3.4.72	Recipient Maximum (HPS file only) .....	70
3.4.73	New Patient Indicator (HPS file only).....	71
3.4.74	Credentialing Begin Date (PMR file only) .....	71
3.4.75	Credentialing End Date (PMR file only) .....	71
3.4.76	Credentialing Flag (PMR file only) .....	72
3.4.77	Submitting Health Plan (PMR file only).....	72
3.4.78	Load Date (PMR file only).....	72
3.4.79	Personnel/Company Name (PMR file only).....	73
3.4.80	Date of Birth (PMR file only) .....	73
3.4.81	Personnel SSN (PMR file only).....	73
3.4.82	Taxpayer ID (PMR file only).....	74
3.4.83	Title Code (PMR file only).....	74
3.4.84	Begin Date (PMR file only).....	74
3.4.85	End Date (PMR file only) .....	75
3.4.86	Criminal Offense Code (PMR file only).....	75
3.4.87	Street Address#1 (PMR file only).....	75
3.4.88	Street Address#2 (PMR file only).....	76
3.4.89	City (PMR file only) .....	76
3.4.90	State (PMR file only).....	76
3.4.91	Zip Code (PMR file only).....	77
3.4.92	COS Code (PMR file only).....	78
3.4.93	COS Description (PMR file only).....	78
3.4.94	COS Begin Date (PMR file only).....	78
3.4.95	COS End Date (PMR file only).....	78
<b>3.5</b>	<b>Appendix 3E - Pharmacy Benefit Manager (PBM) File Layout.....</b>	<b>79</b>
<b>3.6</b>	<b>Appendix 3F – Provider Type Definitions .....</b>	<b>83</b>
3.6.1	BC – Board Certified Behavior Analyst.....	83
3.6.2	C1 – Acupuncturist.....	84
3.6.3	C2 – Federally Qualified Health Center (FQHC) .....	84
3.6.4	C3 – Family Planning Services .....	84
3.6.5	D1 – Dentist – Endodontist .....	84
3.6.6	D2 – Dentist – Pedodontist .....	84
3.6.7	D3 – Dentist – Oral Surgeon.....	84
3.6.8	D4 – Clinic – Dental Services .....	84
3.6.9	01-Group Billing Provider .....	84
3.6.10	Z1-Out-Of-State Middle-Risk Managed Care Only .....	85
3.6.11	02-Hospital.....	85
3.6.12	03-Pharmacy.....	85
3.6.13	04-Laboratory.....	85
3.6.14	05-Clinic .....	85
3.6.15	06-Emergency Transportation .....	85
3.6.16	07-Dentist.....	86

**Hawaii PMMIS  
Hawaii Prepaid Medical Management Information System  
Technical Guide - Provider**

3.6.17	08-MD-Physician.....	86
3.6.18	09-Certified Nurse Midwife.....	86
3.6.19	10-Podiatrist.....	86
3.6.20	11-Psychologist.....	86
3.6.21	12-Certified Registered Nurse Anesthetist .....	87
3.6.22	13-Occupational Therapist.....	87
3.6.23	14-Physical Therapist .....	87
3.6.24	15- Speech/Hearing Therapist .....	87
3.6.25	16-Chiropractor .....	88
3.6.26	17-Naturopath .....	88
3.6.27	18-Physician Assistant.....	88
3.6.28	20-Respiratory Therapist .....	89
3.6.29	21-Massage Therapist .....	89
3.6.30	22-Nursing Home .....	89
3.6.31	23-Home Health Agency.....	89
3.6.32	24-Personal Care Attendant .....	89
3.6.33	25-Developmentally Disabled Group Home .....	89
3.6.34	27-Adult Day Health.....	90
3.6.35	28-Non-emergency Transportation .....	90
3.6.36	29-Community/Rural Health Center.....	90
3.6.37	30-Durable Medical Equipment & Medical Supplies.....	90
3.6.38	31-Osteopath .....	90
3.6.39	32-Medical Foods.....	90
3.6.40	33-Rehabilitation Center .....	90
3.6.41	34-Case Management Services.....	90
3.6.42	35-Hospice.....	91
3.6.43	36-Assisted Living Home/HCBS .....	91
3.6.44	37-Homemaker .....	91
3.6.45	38-Developmentally Disabled Day Care .....	91
3.6.46	39-Habilitation Provider.....	91
3.6.47	40-Attendant Care.....	91
3.6.48	41-Dialysis Clinic.....	91
3.6.49	42-Hospital Affiliated Clinic .....	91
3.6.50	43-Ambulatory Surgical Center.....	91
3.6.51	44-Environmental (LTC).....	92
3.6.52	46-Nurse (Private – RN/LPN) .....	92
3.6.53	47-Registered Dietician.....	92
3.6.54	48-Nutritionist .....	92
3.6.55	49-Assisted Living Center .....	92
3.6.56	50-Adult Foster Care.....	92
3.6.57	51-Behavioral Health Counselor .....	92
3.6.58	52-Mental Health Clinic.....	92
3.6.59	53-Supervisory Care Home .....	93
3.6.60	54-Dental Hygienist.....	93
3.6.61	55-Hotels .....	93
3.6.62	56-Boarding Homes .....	93
3.6.63	57- Residential Treatment Center.....	93
3.6.64	58-School for the Deaf and Blind .....	93

**Hawaii PMMIS  
Hawaii Prepaid Medical Management Information System  
Technical Guide - Provider**

3.6.65	59-Dental Laboratory .....	94
3.6.66	60-Blood Bank.....	94
3.6.67	61-Eye Bank.....	94
3.6.68	62-Audiologist .....	94
3.6.69	63-Drug and Alcohol Rehab.....	94
3.6.70	64-Detox Center .....	94
3.6.71	65-Hospital Outpatient Surgical Center .....	94
3.6.72	66-Organ Bank.....	95
3.6.73	67-Perfusionist .....	95
3.6.74	68-Homeopath .....	95
3.6.75	69-Optometrist .....	95
3.6.76	70-Home Delivered Meals .....	95
3.6.77	71-Psychiatric Hospital .....	95
3.6.78	73-Default Provider .....	95
3.6.79	74-Alternative Residential Facility.....	96
3.6.80	75-MHS Social Worker .....	96
3.6.81	77-Mental Health Rehabilitation.....	96
3.6.82	78-Mental Health Residential Treatment Center .....	96
3.6.83	79-Vision Center .....	96
3.6.84	82-Surgical First Assistant .....	96
3.6.85	83-Free Standing Birthing Center .....	96
3.6.86	84-Licensed Midwife .....	96
3.6.87	86 – Certified Marriage/Family Therapist (CMFT) .....	97
3.6.88	90-QMB Only Provider.....	97
3.6.89	95-Interpreter Services .....	97
3.7	Appendix 3G – Provider Types and Licensing .....	97
3.8	Appendix 3H – State and Territory Code Table.....	99
3.9	Appendix 3I – Med-Quest/Health Plans File Transfers .....	100
3.9.1	Overview .....	100
3.9.2	Availability .....	100
3.9.3	Logon .....	100
3.9.4	Filenames.....	101
3.9.5	Provider Filenames .....	101
3.9.6	Directory Structure .....	102
3.9.7	Prod Folder .....	103
3.9.8	Test Folder .....	103
3.9.9	Other Folder .....	103
3.9.10	Share Info Folder .....	103
3.10	Appendix 3J – Health Plan IDs.....	103
4	Contacts.....	104
4.1	Systems Office .....	104
5	Addendums to the Provider Technical Guide .....	105

# 1 Preface

## 1.1 Overview

The Provider Technical Guide is distributed to medical, dental, and behavioral health plans contracting with the Hawaii Department of Human Services (DHS), Med-QUEST Division (MQD) to further their understanding of the Hawaii Prepaid Medical Management Information System (HPMMIS). This Provider Technical Guide contains the provider file layouts, code tables and FTP process to be used by health plans to provide information to and receive information from MQD through HPMMIS. HPMMIS is operated and maintained by the State of Arizona Medicaid agency known as the Arizona Health Care Cost Containment System Administration (AHCCCS).

## 1.2 Provider Registration and Affiliation

Health plans are required to submit monthly electronic files of their entire health plan provider network (HPS). HPMMIS receives provider registrations and updates from the online provider portal – HOKU (Hawaii's Online Kahu Utility). HPMMIS then updates the provider master registry file (PMR) which is used when editing encounters submitted by the health plans. HPMMIS will provide the HPS electronic error report to the plans.



### 1.3 Conventions Used in this Manual

Unless otherwise stated, the following terms are used in this manual as defined below.

CLIA	Clinical Laboratory Improvement Act
CMS	Centers for Medicare and Medicaid Services (formerly known as HCFA)
DCCA	State of Hawaii Department of Commerce and Consumer Affairs
DHS	Department of Human Services
ECC	Enrollment Call Center in MQD which processes health plan enrollment choices.
KOLEA	Kauhale On-Line Eligibility Assistance
HCFA	Health Care Financing Administration (former name of CMS)
Health plan	Health plans include medical, dental, and behavioral health plans contracted with the State of Hawaii to provide services to eligible members.
HPMMIS	The Hawaii Prepaid Medical Management Information System is based on the Arizona PMMIS and is operated and maintained by the State of Arizona for Hawaii.
HPS	Health Plan Provider Network (plan submittal) file that is submitted monthly by the health plans to HPMMIS.
MQD	MQD is the Med-QUEST Division of the Hawaii Department of Human Services.
MFIS	MFIS is the Member File Integrity Section in MQD, which resolves membership roster problems.
PMR	Provider Master Registry, which is maintained by HPMMIS, of all providers who are in the HPMMIS Provider database.
SFTS	Secure File Transfer Server (also known as SFTP or EFT)
TPL	Third Party Liability
VPN	Virtual Private Network
PBM	Pharmacy Benefit Manager

## 2 Provider Interface

### 2.1 Health Plan Provider Network

Each health plan is required to develop and maintain a sufficient provider network to provide the required health services to its members in a timely manner. In most situations, the provider network consists of providers on contract with the health plans. Sometimes, the health plan will authorize services to be provided by a provider out-of-network or not on contract with the health plan. Both types of providers (on contract and not) **must register with our HOKU (Hawaii’s Online Kahu Utility) provider portal, (with limited exceptions - refer to CMS Medicaid Provider Enrollment Compendium (MPEC) dated 12/29/2023, Section 1.5.1, subsection C. Furnishing Providers).**

#### 2.1.1 Provider Registry Definitions

A list of provider registry definitions appears below.

Health Plan Provider Network (HPS)	In each health plan, the provider network is the conglomeration of the required components or types of providers to provide the required health services to the recipient. The provider network must be sufficient in size within the health plan’s service area to provide the needed services to the recipient in a timely manner. The HPS is reported electronically monthly to MQD.
Provider Master Registry (PMR)	This is the registry maintained by MQD of all QUEST providers and is placed on the SFTS server on a monthly basis. The health plan can use the PMR to obtain all QUEST IDs for its providers
Health Plan Monthly Error File (HPQ)	When the HPS (Health Plan Monthly Submission) file is processed, it will generate this output file that will contain provider records which have not passed the HPS process edits.
HOKU	Hawaii’s Online Kahu Utility. Online utility portal for providers to register with Med-QUEST.

Hawaii PMMIS  
Hawaii Prepaid Medical Management Information System  
Technical Guide - Provider

Primary Care Provider (PCP)	A primary care provider is a state-licensed physician or a nurse practitioner contracted by a participating health plan to assess an enrollee’s health care needs and provide services to meet those needs either directly or through the plan’s provider network. A primary care provider who is a nurse practitioner shall be a family nurse practitioner, pediatric nurse practitioner, or (if the enrollee is a pregnant woman) a nurse midwife.
Provider Record	A provider record consists of several sub-record types about providers in the health plan servicing QUEST recipients: Master record Address Group affiliation Specialty License Type EPSDT Contact CLIA NPI Membership (HPS file only) Enrollment Credentialing Ownership-Personnel Category of Service
Pharmacy Benefit Manager (PBM)	This is a weekly file (generated on Sundays) of MQD providers that can prescribe or dispense pharmacy supplies. The file will be placed in MQD’s SFTP folder: /shareinfo/Provider/prod/OUT.

## 2.2 Preparing Provider Data for Health Plan Submission (HPS) File

When reporting provider data to MQD, a health plan must apply the following guidelines to assure consistent and accurate data. Provider registry data is reported using eleven different record types, each of which is described below with clarification of the related data elements. For further understanding of the required data submission, refer to Appendix 3A – Provider Master Registry / Health Plan Provider Network and Appendix 3D – Provider Health Plan

Submission (HPS) and Provider Master Registry (PMR) Record Index/Data Elements.

## 2.2.1 Provider Submission Cycle

The health plans must submit electronically a Health Plan Submission (HPS) file via the SFTS process either on the 1<sup>st</sup> or 3<sup>rd</sup> Weds of each month. Although the HPS file can be submitted anytime, the submission date on the filename must reflect the date of the next processing Wednesday. The latest a provider file can be submitted on a processing Wednesday is 5:00 p.m. HST.

## 2.2.2 General Guidelines

### 2.2.2.1 Required Data Elements

Most of the data elements are required for completeness of each provider profile. If the data element is not applicable to a particular provider profile, then the record is considered to be conditional.

### 2.2.2.2 Field Values

To assure consistency and accuracy of the data for the DATE fields, the format is CCYYMMDD. Any date fields that should remain open, such as an End Date, must be filled with 99999999.

All character data should be left justified with trailing blanks and in capital letters. All numeric data should be right justified with leading zeroes. If the data for a character field is not applicable, fill the complete field with blanks. If the data for a numeric field is not applicable, fill the complete field with zeroes. If the character field is not applicable, fill the complete field with spaces. All provider sub-records (for example, BB, CC, DD, etc.) will follow the master record to which they apply. Multiple sub-records that apply to a distinct provider will be grouped together.

### 2.2.3 Master Record (AA)

The master record consists of the general identifying information for the provider. It is a required record to establish the provider profile. The following topics warrant clarification to understand the provider information to be submitted and to obtain accurate provider data from the health plans.

#### Provider Type

Provider types are grouped by type of services rendered. Examples are hospital, physician, dentist, DME supplier, and Case Management Agencies. Select the appropriate Provider Type Code listed in Appendix 3B – Provider Codes and Values sub-section 3.2.4 Provider Type Codes.

### 2.2.4 Address Record (BB)

Providers may have different addresses for the location of services, billing, and mailing. Correct address data will assure reliable data analysis for reporting purposes. This is a required record for all provider types with the exception of 01 Provider types.

### 2.2.5 Group Record (CC)

If a provider is not associated with a group, the CC Record should not be completed. Submit a group record for individual providers associated with a group practice. This is a conditionally required record. Not all providers are participants of a group practice. This record is required for individuals who are members of a group practice. An AA record needs to be established for the group practice with associated records to establish the group's profile. The Group ID field should contain the provider identification number of the provider's group. For example, Dr. Smith is a member of the Johnson group. Submit AA master records for both Dr. Smith and the Johnson group. Also submit a CC record for Dr. Smith that will indicate he or she is a member of the Johnson group. Do not submit a Group Record for '01-Group Billing' providers since a group cannot be associated with itself or another '01-Group Billing' provider.

### 2.2.6 Specialty Record (DD)

Some providers may specialize in a type of service or treatment of certain medical conditions. For the physicians, the specialty is determined by the Specialty Board Certification requirements. The Department of Health certifies the nurse practitioner specialty. Other providers and non-licensed providers must select their specialty from the Provider Specialty/Subspecialty Codes list found in Appendix 3B – Provider Codes and Values sub-section 3.2.5 Provider Specialty Codes. This is not a required record for providers.

Specialty begin and end dates are the effective and expiration dates, respectively, for the provider's specialty within the health plan. The specialty begin date must be completed for every specialty record on a provider. Indicate open-ended end dates with nines (99999999).

When a provider has more than one specialty record, the Primary Indicator will identify if the specialty record is the primary specialty of the provider.

For example, a pediatric endocrinologist would have the following specialties:

- 150 – Pediatrician
- 156 – Pediatric - Endocrinology
- 063 – Endocrinology

The primary indicator would be Y (yes) for 150 and N (no) for 156 and 063. Each specialty requires an individualized DD record to be submitted.

The PCP Indicator shows the provider has been designated as a primary care provider within the health plan and is eligible to have a PCP relationship with a recipient.

### 2.2.7 EPSDT Record (EE)

This record is used to indicate the dates for which a provider was authorized to provide EPSDT services to a health plan's population. This record is conditional; if no information is provided for a set of dates, it is presumed that the provider was not an EPSDT provider on those dates.

### 2.2.8 License Record (FF)

Not all provider types require a license to practice their specialty. If the provider does not require a license the FF record should not be completed.

#### License Number

The Department of Commerce and Consumer Affairs (DCCA) issues the licenses for such medical professions as physicians, pharmacies, psychologists, physical therapists, nurse midwives and other provider types.

The Department of Health (DOH) certifies ambulance (air and ground) service providers, nurse practitioners, hospitals, home health agencies and other provider types.

Exception: Non-professional, non-licensed providers include commercial airlines, and taxi companies.

## 2.2.9 Contract Dates Record (GG)

This record is used to indicate which providers were in a health plan's network for which dates. This record is required as MQD loads the Contract Dates into HOKU.

## 2.2.10 CLIA Record (HH)

This record is used to indicate which providers are certified to provide laboratory services under the Clinical Laboratory Improvement Act. This record is conditional if the provider is not certified to provide laboratory services under the Clinical Laboratory Improvement Act. If the provider is a certified CLIA provider then it is expected that the current CLIA information will be provided.

## 2.2.11 Reimbursement Type Record (II)

This record provides miscellaneous data to the health plans as well as to Med-QUEST departments that have requested this type of data previously. It is created for the PMR (Provider Master Registry) file only. Health plans should not generate this record.

## 2.2.12 Enrollment Record (JJ)

This record provides the Health Plans and Med-QUEST departments with a provider's enrollment dates. There may be more than one enrollment date segment for each provider record which details dates on which the provider was made active or dates on which they were terminated. It is created for the PMR (Provider Master Registry) file only. Health plans should not generate this record.

## 2.2.13 NPI Record (KK)

This record provides the NPI that was received by Med-QUEST from the providers. There may be more than one NPI for each provider. This record is created for the PMR (Provider Master Registry) file only. Health plans should not generate this record.

### 2.2.14 Membership Record (LL)

This record will be generated by the health plans and should be included in the monthly health plan submissions (HPS) file only. It should be generated if a provider is a pcp and should contain membership information. It will not be included in the PMR file to the health plans.

### 2.2.15 Provider Credentialing Record (MM)

This record will be used to report if a provider has been credentialed or not and the date range for the credentialing. This record is created for the PMR (Provider Master Registry) file only. Health plans should not generate this record.

### 2.2.16 Ownership-Personnel Record (NN)

This record will be used to report ownership/personnel data of providers whose provider type is found in [Section 3.2.7](#) (Provider Types Requiring Ownership-Personnel Data) as per CMS mandates:

§455.104 Disclosure by Medicaid providers and fiscal agents: Information on ownership and control

§455 Subpart E Provider Screening and Enrollment

This record is created for the PMR (Provider Master Registry) file only. Health plans should not generate this record.

### 2.2.17 Category of Service (OO)

This record will be used to report the Categories of Service found under each provider's profile in our system. It is created for the PMR (Provider Master Registry) file only. Health plans should not generate this record.

## 2.3 Processing Provider Network Submissions

Each health plan submits their entire provider network to MQD electronically using the plan provider network record layout, which is identical to the Provider Master Registry (PMR) record layout. The plans' submitted networks are processed in HPMMIS & HOKU. The following files are returned to the plans:

Provider Master Registry, which includes all QUEST providers with the QUEST IDs

Report of errors encountered during processing the network file



Formats for these files are contained in these appendices:

- [Appendix 3A – Provider Master Registry / Health Plan Provider Network](#)
- [Appendix 3B – Provider Codes and Values](#)
- [Appendix 3C – Provider Error Reports](#)
- [Appendix 3D – Provider Health Plan Submission \(HPS\) and Provider Master Registry \(PMR\) Record Index/Data Elements](#)
- [Appendix 3E – Provider Type Definitions](#)
- [Appendix 3F – Provider Types and Licensing](#)
- [Appendix 3G – State and Territory Code Table](#)
- [Appendix 3H – Med-Quest/Health Plans File Transfers](#)
- [Appendix 3I – Health Plan IDs](#)

## 2.4 Provider Master Registry (PMR)

The provider master registry contains all providers in the HPMMIS provider database, regardless of health plan affiliation. The registry is provided to plans on the MQD SFTS server following processing of the health plans' provider network files. The record format for the provider master registry is the same as that used by the health plans to submit their provider networks.

The health plan ID and health plan provider ID are blank on the provider master registry because it is not health plan specific. The provider status field contains the enrollment status reflected in HPMMIS for the provider:

- Active
- Terminated
- Pended
- Suspended
- Denied

## 2.5 File Transfer and Retention

Monthly provider files remain on the MQD SFTS server for 90 days before being backed up and deleted by Med-QUEST. For detailed information regarding file transfer procedures, refer to Appendix 3H – Med-Quest/Health Plans File Transfers.

## 2.6 Provider File Testing

The provider test process can be run upon a health plan's request. Because it will be run during the day, a test file must be submitted to the SFTP by 12:00 p.m. HST on the requested process day and the process date must be on the filename. The request must be made to the MQD Systems Office via email after the file is placed on the SFTP. Any files placed on the SFTP after 12:00 p.m. HST is subject to be processed the next business day and should have the appropriate process date on the filename.

## 3 Appendices

The file formats in this section are used to communicate provider information between HPMMIS and the health plan.

### 3.1 Appendix 3A – Provider Master Registry / Health Plan Provider Network

#### 3.1.1 File Header Record Format

#	Data Name	Size	Type	Actual Position		Remarks
				From	To	
1	Health Plan ID	6	AN	01	06	Unique 6-character health plan ID
2	Current Date	8	N	07	14	CCYYMMDD
3	File Type Code	2	AN	15	16	PN = Provider Network
4	Filler	284	AN	17	300	Reserved for future use

#### 3.1.2 AA Master Record

#	Data Name	Size	Type	Actual Position		Remarks
				From	To	
1	Record Type	2	AN	01	02	Indicates provider master record; value AA
2	Health Plan ID	6	AN	03	08	Unique 6-character health plan ID. (In PMR file, this field will have 'HPMMIS').

**Hawaii PMMIS**  
**Hawaii Prepaid Medical Management Information System**  
**Technical Guide - Provider**

3	Health Plan Provider ID	12	AN	09	20	Health Plan issued Provider ID. (In PMR file, this field will have spaces).
4	QUEST Provider ID	6	AN	21	26	Provider ID
5	Filler	32	AN	27	58	Reserved for future use
6	Name	40	AN	59	98	Registered business name or Provider's Last/First Name
7	SSN	9	AN	99	107	Social security number
8	Provider Type	2	AN	108	109	Code classifying the provider by type of services rendered. (Refer to Appendix 3E – Provider Type Definitions.)
9	Provider Status	2	AN	110	111	2 digit code that identifies if provider is Active, Terminated, or Restricted
10	NPI	10	N	112	121	National Provider Identifier
11	NPI Begin date	8	N	122	129	CCYYMMDD; Effective Date of NPI
12	Date of Birth	8	N	130	137	CCYYMMDD; Provider's Date of Birth
13	Gender	1	AN	138	138	Provider's Gender
14	Language Code 1	2	AN	139	140	Refer to 3.2.10 Language Codes Table (HPS file only) In PMR, this field will have spaces.
15	Language Code 2	2	AN	141	142	Refer to 3.2.10 Language Codes Table (HPS file only) In PMR, this field will have spaces.
16	Language Code 3	2	AN	143	144	Refer to 3.2.10 Language Codes Table (HPS file only) In PMR, this field will have spaces.
17	Language Code 4	2	AN	145	146	Refer to 3.2.10 Language Codes Table (HPS file only) In PMR, this field will have spaces.
18	Filler	154	AN	147	300	Reserved for future use

### 3.1.3 BB – Address Record

#	Data Name	Size	Type	Actual Position		Remarks
				From	To	
1	Record Type	2	AN	01	02	Indicates provider address record; value BB
2	Health Plan ID	6	AN	03	08	Unique 6-character health plan ID. (In PMR file, this field will have 'HPMMIS').
3	Health Plan Provider ID	12	AN	09	20	Health Plan issued Provider ID. (In PMR file, this field will have spaces).
4	QUEST Provider ID	6	AN	21	26	Provider ID

**Hawaii PMMIS**  
**Hawaii Prepaid Medical Management Information System**  
**Technical Guide - Provider**

5	Location Code	2	AN	27	28	Indicates Service address location code
6	Address Type	1	AN	29	29	C = Correspondence, P = Payment, or S = Service
7	FEIN or Tax ID number	9	AN	30	38	Federal Employer Identification Number
8	Send Mail Here Indicator	1	AN	39	39	Send Mail Here Indicator
9	Street Address #1	40	AN	40	79	Address line 1; free text
10	Street Address #2	40	AN	80	119	Address line 2; free text
11	City	20	AN	120	139	City; free text
12	State	2	AN	140	141	State abbreviation; USPS standard
13	Zip Code	9	AN	142	150	Zip + 4 or zip
14	Address Begin Date	8	N	151	158	CCYYMMDD; effective date of provider's address
15	Address End Date	8	N	159	166	CCYYMMDD; end date of a provider's address
16	Filler	134	AN	167	300	Reserved for future use.

### 3.1.4 CC – Group Record

#	Data Name	Size	Type	Actual Position		Remarks
				From	To	
1	Record Type	2	AN	01	02	Indicates provider group record; value CC (optional if no affiliation)
2	Health Plan ID	6	AN	03	08	Unique 6-character health plan ID. (In PMR file, this field will have 'HPMMIS').
3	Health Plan Provider ID	12	AN	09	20	Health Plan issued Provider ID. (In PMR file, this field will have spaces).
4	QUEST Provider ID	6	AN	21	26	Provider ID
5	Filler	2	AN	27	28	Reserved for future use
6	Health Plan Group ID	12	AN	29	40	Spaces
7	QUEST Group Provider ID	6	AN	41	46	Provider ID for group provider
8	Filler	2	AN	47	48	Reserved for future use
9	Group Begin Date	8	N	49	56	CCYYMMDD; effective date of group provider's affiliation with provider
10	Group End Date	8	N	57	64	CCYYMMDD; expiration date of group provider's affiliation with provider
11	Filler	236	AN	65	300	Reserved for future use

### 3.1.5 DD – Specialty Record

#	Data Name	Size	Type	Actual Position		Remarks
				From	To	
1	Record Type	2	AN	01	02	Indicates provider specialty record; value DD (optional if no specialty)
2	Health Plan ID	6	AN	03	08	Unique 6-character health plan ID. (In PMR file, this field will have 'HPMMIS').
3	Health Plan Provider ID	12	AN	09	20	Health Plan issued Provider ID. (In PMR file, this field will have spaces).
4	QUEST Provider ID	6	AN	21	26	Provider ID
5	Filler	2	AN	27	28	Reserved for future use
6	Primary Indicator	1	AN	29	29	Spaces
7	Specialty Code	3	AN	30	32	Provider specialty code
8	Begin Date	8	N	33	40	CCYYMMDD; effective date of provider's specialty
9	End Date	8	N	41	48	CCYYMMDD; expiration date of provider's specialty
10	PCP Indicator	1	AN	49	49	Y or N (spaces on PMR)
11	PCP Spec Indicator	1	AN	50	50	B, 6 or N (PMR file only)
12	Attestation Date	8	N	51	58	Date of Self Attestation (PMR file only)
13	Filler	242	AN	59	300	Reserved for future use

### 3.1.6 EE – EPSDT Record

#	Data Name	Size	Type	Actual Position		Remarks
				From	To	
1	Record Type	2	AN	01	02	Indicates EPSDT type record; value EE
2	Health Plan ID	6	AN	03	08	Unique 6-character health plan ID. (In PMR file, this field will have 'HPMMIS')
3	Health Plan Provider ID	12	AN	09	20	Health Plan issued Provider ID. (In PMR file, this field will have spaces)
4	QUEST Provider ID	6	AN	21	26	Provider ID
5	Filler	2	AN	27	28	Reserved for future use
6	Begin Date	8	N	29	36	CCYYMMDD; effective date of provider's EPSDT COS '08'
7	End Date	8	N	37	44	CCYYMMDD; expiration date of provider's EPSDT COS '08'
8	Filler	256	AN	45	300	Reserved for future use

### 3.1.7 FF – License Type Record

#	Data Name	Size	Type	Actual Position		Remarks
				From	To	
1	Record Type	2	AN	01	02	Indicates License type record; value FF
2	Health Plan ID	6	AN	03	08	Unique 6-character health plan ID. (In PMR file, this field will have 'HPMMIS').
3	Health Plan Provider ID	12	AN	09	20	Health Plan issued Provider ID. (In PMR file, this field will have spaces).
4	QUEST Provider ID	6	AN	21	26	Provider ID
5	Filler	2	AN	27	28	Reserved for future use
6	Agency ID	3	AN	29	31	Indicates licensing agency
7	DEA Level	1	AN	32	32	Indicates DEA level if license is 017 DEA otherwise it is not used
8	License Number	15	AN	33	47	license or certificate number
9	License Effective Date	8	N	48	55	CCYYMMDD
10	License Expiration Date	8	N	56	63	CCYYMMDD
11	Filler	237	AN	64	300	Reserved for future use

### 3.1.8 GG – Contract Record

#	Data Name	Size	Type	Actual Position		Remarks
				From	To	
1	Record Type	2	AN	01	02	Indicates contract type record; value GG
2	Health Plan ID	6	AN	03	08	Unique 6-character health plan ID. (In PMR file, this field will have 'HPMMIS').
3	Health Plan Provider ID	12	AN	09	20	Health Plan issued Provider ID. (In PMR file, this field will have spaces).
4	QUEST Provider ID	6	AN	21	26	Provider ID
5	Filler	2	AN	27	28	Reserved for future use
6	Begin Date	8	N	29	36	CCYYMMDD; enrollment begin date
7	End Date	8	N	37	44	CCYYMMDD; enrollment end date
8	Filler	256	AN	45	300	Reserved for future use

### 3.1.9 HH – CLIA Record

#	Data Name	Size	Type	Actual Position		Remarks
				From	To	
1	Record Type	2	AN	01	02	Indicates CLIA type record; value HH
2	Health Plan ID	6	AN	03	08	Unique 6-character health plan ID. (In PMR file, this field will have 'HPMMIS').
3	Health Plan Provider ID	12	AN	09	20	Health Plan issued Provider ID. (In PMR file, this field will have spaces).
4	QUEST Provider ID	6	AN	21	26	Provider ID
5	Filler	2	AN	27	28	Reserved for future use
6	CLIA Number	10	AN	29	38	CLIA unique laboratory ID for agency 200 only
7	Street Address #1	40	AN	39	78	Street address line 1 for CLIA lab
8	Street Address #2	40	AN	79	118	Spaces
9	City	20	AN	119	138	City
10	State	2	AN	139	140	State
11	Zip	9	AN	141	149	Postal zip code
12	Begin Date	8	N	150	157	CCYYMMDD; License issue date
13	End Date	8	N	158	165	CCYYMMDD; License end date
14	Filler	135	AN	166	300	Reserved for future use

### 3.1.10II – Reimbursement Type (PMR File Only)

#	Data Name	Size	Type	Actual Position		Remarks
				From	To	
1	Record Type	2	AN	01	02	Indicates Reimbursement type record; value II
2	Health Plan ID	6	AN	03	08	HPMMIS
3	Health Plan Provider ID	12	AN	09	20	Spaces
4	QUEST Provider ID	6	AN	21	26	Provider ID
5	Location Code	2	AN	27	28	Indicates Service address location code
6	Address Type	1	AN	29	29	C = Correspondence, P = Payment, or S = Service
7	Attention	40	AN	30	69	Address attention line
8	Phone	10	AN	70	79	Address Phone
9	FAX	10	AN	80	89	Address Fax
10	Reimbursement Type	2	AN	90	91	Provider reimbursement type if address type = "C" only otherwise spaces
11	Reimbursement Begin Date	8	AN	92	99	Provider begin date of reimbursement type if address type = "C" only otherwise spaces. Format

**Hawaii PMMIS**  
**Hawaii Prepaid Medical Management Information System**  
**Technical Guide - Provider**

						CCYYMMDD
12	Reimbursement End Date	8	AN	100	107	Provider end date of reimbursement type if address type = "C" only otherwise spaces. Format CCYYMMDD or may be all '9's.
13	Filler	193	AN	108	300	Reserved for future use



### 3.1.11 JJ – Enrollment Record (PMR File Only)

#	Data Name	Size	Type	Actual Position		Remarks
				From	To	
1	Record Type	2	AN	01	02	Indicates enrollment record; value JJ
2	Health Plan ID	6	AN	03	08	HPMMIS
3	Health Plan Provider ID	12	AN	09	20	Spaces
4	QUEST Provider ID	6	AN	21	26	Provider ID
5	Provider Status Type	1	AN	27	27	Indicates enrollment status. A = Active, P = Pended, I = Inactive, D = Denied, S = Suspended, T = Terminated
6	Provider Status Code	2	AN	28	29	Indicates code for enrollment status. (Refer to 3.2.3 <u>Provider Status Codes (PMR Only) Provider Status Codes (PMR Only)</u> ).
7	Status Begin Date	8	AN	30	37	Enrollment begin date.
8	Status End Date	8	AN	38	45	Enrollment end date.
9	Replacement Provider ID	6	AN	46	51	Replacement provider ID for certain terminated providers.
10	Filler	249	AN	52	300	Reserved for future use

### 3.1.12 KK – NPI Record (PMR File Only)

#	Data Name	Size	Type	Actual Position		Remarks
				From	To	
1	Record Type	2	AN	01	02	Indicates NPI record; value KK
2	Health Plan ID	6	AN	03	08	HPMMIS
3	Health Plan Provider ID	12	AN	09	20	Spaces
4	QUEST Provider ID	6	AN	21	26	Provider ID
5	NPI	10	AN	27	36	National Provider Identifier
6	NPI Begin Date	8	AN	37	44	
7	NPI End Date	8	AN	45	52	
8	Filler	248	AN	53	300	Reserved for future use

### 3.1.13 LL – Membership Record (Health Plan Submission file only)

#	Data Name	Size	Type	Actual Position		Remarks
				From	To	
1	Record Type	2	AN	01	02	Indicates membership record; value LL
2	Health Plan ID	6	AN	03	08	6 char health plan id
3	Health Plan Provider ID	12	AN	09	20	Provider number assigned by health plan
4	QUEST Provider ID	6	AN	21	26	Provider ID
5	Location Code	2	AN	27	28	Location Code
6	Island	2	AN	29	30	Island Code
7	Recipient Count	5	N	31	35	Member Count
8	Recipient Max	5	N	36	40	Member Limit
9	New Patient Indicator	1	AN	41	41	Accept new patients (Y/N)
10	Filler	125	AN	42	166	Filler

### 3.1.14 MM – Credentialing Record (PMR File Only)

#	Data Name	Size	Type	Actual Position		Remarks
				From	To	
1	Record Type	2	AN	01	02	Value "MM"
2	Health Plan ID	6	AN	03	08	Unique 6-character health plan ID. (In PMR, this field will have 'HPMMIS').
3	Health Plan Provider ID	12	AN	09	20	Health Plan issued Provider ID. (In PMR, this field will have spaces).
4	QUEST Provider ID	6	AN	21	26	Provider ID
5	Begin Date	8	AN	27	34	CCYYMMDD
6	End Date	8	AN	35	42	CCYYMMDD
7	Credentialing Successful	1	AN	43	43	"Y" or "N"
8	Submitting Health Plan ID	6	AN	44	49	Spaces. (In PMR – this field will have the Health Plan that submitted the credentialed record).
9	Load Date	8	AN	50	57	Spaces. (In PMR – this field will have the date the rec was loaded into HPMMIS from health plans HPA file. NOTE: Effective August 2020, HPA file submission has been discontinued).
10	Filler	243	AN	58	300	Reserved for future use

Hawaii PMMIS  
Hawaii Prepaid Medical Management Information System  
Technical Guide - Provider

### 3.1.15 NN - Ownership-Personnel Record (PMR File Only)

#	Data Name	Size	Type	Actual Position		Remarks
				From	To	
1	Record Type	2	AN	01	02	Indicates Ownership/Personnel record; value NN
2	Health Plan ID	6	AN	03	08	Unique 6-character Health Plan ID Required
3	Health Plan Provider ID	12	AN	09	20	Prov ID from Health Plan
4	QUEST Provider ID	6	AN	21	26	New Provider ADD: Spaces Existing Provider: QUEST PR-ID
5	Personnel/Company Name	25	AN	27	51	Personnel Name or Company Name  Personnel Name format: last name/first name  Company Name format: no '/'
6	DOB	8	N	52	59	CCYYMMDD; Date of Birth (In PMR file, this field will have spaces).
7	Personnel SSN	9	N	60	68	Social Security Number (In PMR file, this field will have spaces).
8	Taxpayer ID	9	N	69	77	Taxpayer Identification Number (In PMR file, this field will have spaces).
9	Title Code	2	AN	78	79	Refer to Title Codes table in <a href="#">Section 3.2.8</a> (In PMR file, this field will have spaces).
10	Begin Date	8	N	80	87	CCYYMMDD; Effective Date of Title (In PMR file, this field will have spaces).
11	End Date	8	N	88	95	CCYYMMDD; End Date of Title (In PMR file, this field will have spaces).
12	Criminal Offense Code	3	AN	96	98	Refer to Criminal Offense Codes table in <a href="#">Section 3.2.9</a> . (In PMR file, this field will have spaces).

**Hawaii PMMIS**  
**Hawaii Prepaid Medical Management Information System**  
**Technical Guide - Provider**

13	Street Addr#1	55	AN	99	153	Address line 1; free text (In PMR file, this field will have spaces).
14	Street Addr#2	55	AN	154	208	Address line 2; free text (In PMR file, this field will have spaces).
15	City	25	AN	209	233	City; free text (In PMR file, this field will have spaces).
16	State	2	AN	234	235	State abbreviation; USPS Standard. (In PMR file, this field will have spaces).
17	Zip Code	5	N	236	240	5 digit Zip Code only (In PMR file, this field will have spaces).
18	Filler	60	AN	241	300	For future use

### 3.1.16 OO – Category of Service Record (PMR File Only)

	Actual Position			Actual Position		
#	Data Name	Size	Type	From	To	Remarks
1	Record Type	2	AN	01	02	Indicates COS record: OO
2	Health Plan ID	6	AN	03	08	Unique 6-character Health Plan ID For PMR: Always = HPMMIS
3	Health Plan Provider ID	12	AN	09	20	Prov ID from Health Plan For PMR: Always = 'spaces'
4	QUEST Provider ID	6	AN	21	26	QUEST PR-ID; HPMMIS PR-ID
5	COS Code	2	AN	27	28	HPMMIS Category of Service Code
6	COS Description	41	AN	29	69	Description of Category of Service Code
7	Begin Date	8	N	70	77	CCYYMMDD; Effective date of COS
8	End Date	8	N	78	85	CCYYMMDD; End date of COS
9	Filler	215	AN	86	300	For future use

### 3.1.17 File Trailer Record Format

#	Data Name	Size	Type	Actual Position		Remarks
				From	To	
1	Trailer Indicator	6	AN	01	06	ZZZZZZ
2	Current Date	8	N	07	14	CCYYMMDD
3	Total Count	6	N	15	20	Total number of records (including header and trailer records)
4	Filler	280	AN	21	300	Reserved for future use

## 3.2 Appendix 3B – Provider Codes and Values

### 3.2.1 Agency Codes

Agency Code	Description
009	Alcohol and Drug Abuse Division - DOH
010	HCFA State Survey Agency
017	Drug Enforcement Agency
020	Board of Acupuncture
025	Advanced Practice Registered Nurse Program
050	Tax Clearance
051	Comprehensive General Liability
052	Professional Liability
053	Automobile Liability
054	Expanded Care Adult Residential Care Home
055	DHS Child Foster License
056	Certification/License Foster Home
057	Hawaii Drivers License
058	C.N.A. License
059	Non-Profit Approval From IRS
060	Board of Behavior Analyst
061	Adult Day Care
062	H&CB Case Management Agency
063	Bloodborne Pathogens
064	First Aid
065	CPR
066	Tuberculin Clearance
068	Assisted Living Facility
070	Hawaii Criminal Justice Data Center
130	Board of Chiropractic Examiners
200	HCFA/CLIA (Clinical Laboratory Improvement)
220	Board of Dental Examiners
230	Dispensing Opticians Program
500	Hearing Aid Dealers and Fitters Program
560	Marriage and Family Therapists Program
620	Board of Massage Therapy
630	Board of Medical Examiners

Hawaii PMMIS  
Hawaii Prepaid Medical Management Information System  
Technical Guide - Provider

Agency Code	Description
720	Board of Examiners in Naturopathy
750	Board of Nursing
760	Nursing Home Administrator Program
770	Occupational Therapy Program
780	Board of Examiners in Optometry
790	HI Board of Osteopathic Examiners
820	Board of Pharmacy
825	Board of Physical Therapy
850	Professional Corporations
860	Board of Psychology
920	Social Worker Program
930	Board of Speech Pathology and Audiology

### 3.2.2 License Type Codes

License Type Code	Description
ACU	Acupuncturist
AMD	Certified Physicians Assistant
APRN	Advanced Practice Registered Nurse
AUD	Audiologist
BA	Behavior Analyst
DC	Chiropractor
DH	Dental Hygienist
DIB	Dispensing Optician Business
DIO	Dispensing Optician
DOS	Osteopathic Physician and Surgeon
DT	Dentist
HA	Hearing Aid Dealer and Fitter
LPN	Licensed Practical Nurse
LSW	Licensed Social Worker
LTD	Limited Practical Nurse
MAE	Massage Establishment
MAT	Massage Therapist
MD	Physician
ND	Naturopath
NHA	Nursing Home Administrator
OD	Optometrist
OT	Occupational Therapist
PCC	Chiropractic Professional Corporation
PCD	Dental Professional Corporation
PCM	Medical Professional Corporation
PCOP	Optometry Professional Corporation
PCOS	Osteopathic Professional Corporation
PH	Pharmacist
PHY	Pharmacy

Hawaii PMMIS  
Hawaii Prepaid Medical Management Information System  
Technical Guide - Provider

<b>License Type Code</b>	<b>Description</b>
PO	Podiatrist
PSY	Psychologist
PT	Physical Therapy
RN	Registered Nurse
RX	APRN - Prescriptive Authority
SP	Speech Pathology
SW	Social Worker

### 3.2.3 Provider Status Codes (PMR Only)

Provider Status Code	Description
01	Active
02	Active-Unlicensed Nursing Home/Hospice
03	Active-Decertified for SNF/ICF
04	Active-Decertified for Hospice
05	Active-Decertified for SNF/ICF, Hospice
07	Pending - In process
09	Pending – NPI missing
10	Pending-Address missing
11	Pending-Reimbursement type missing
12	Pending-License/Certification missing
13	Pending-Category of service missing
14	Pending-Specialty missing
15	Pending-Rate schedule missing
16	Pending-Affiliation missing
17	Pending-Non-categorical deduction missing
18	Pending-Tax ID Ownership Invalid
19	Pending-Owner/Provider IDs do not match
20	Pending-Not Owner/Provider IDs Match
21	Pending-Provider contract missing
22	Pending-Service address Pay to Location Blank
25	Terminated by MQD
26	Decertified by Program Contractor
27	Terminated-no provider agreement
28	Terminated-failure to recertify
29	Terminated-no activity in 12 months
30	Terminated-other
31	Terminated-no activity in 24 months
32	Terminated-death
33	Terminated-moved out of state
34	Terminated-voluntary
35	Terminated-multiple provider id (MMIS)
36	Terminated-License terminated Board of Dental Examiners.
37	Terminated-License terminated Board of Medical Examiners
38	Terminated-License terminated Board of Nursing
39	Terminated-License terminated Board of Optometry
40	Terminated-License terminated Board of Osteopath
41	Terminated-License terminated Board of Pharmacy
42	Terminated-License terminated Board of Psychology
44	Terminated-HCFA mandated
45	Terminated-Radiation Reg
46	Terminated-License terminated Board of Podiatry
47	Terminated-License terminated Board of Chiropractic
48	Terminated-License terminated board of Speech/hearing
49	Terminated-License terminated Board of Physical Therapy



Hawaii PMMIS  
Hawaii Prepaid Medical Management Information System  
Technical Guide - Provider

Provider Status Code	Description
50	Terminated-License terminated Board of Respiratory
51	Terminated-ownership change
52	Terminated-provider type change
53	Terminated-multiple ids (HPMMIS)
54	Terminated-returned mail
55	Terminated-retired
56	Terminated-out of business
57	Terminated-License terminated Board of Occupational Therapy
58	Suspension – non payment
59	Termination-EVS Provider
60	Suspended-other
61	Suspended-License suspended Board of Dental Examiners
62	Suspended-License suspended Board of Medical Examiners
63	Suspended-License suspended Board of Nursing
64	Suspended-License suspended Board of Optometry
65	Suspended-License suspended Board of Osteopath
66	Suspended-License suspended Board of Pharmacy
67	Suspended-License suspended Board of Psychology
68	Suspended-License suspended Dept. of Health
69	Suspended-License suspended HCFA Mandated
70	Suspended-License suspended Radiation Regulations
71	Suspended-License suspended Board of Podiatry
72	Suspended-License suspended Board of Chiropractic
73	Suspended-License suspended Speech and Hearing
74	Suspended-License suspended Board of Physical Therapy
79	Terminated-Application Fee Not Received
80	Conv Active-Address Missing
81	Conv Active-Reimburse Type Missing
82	Conv Active-License/Cert Missing
83	Conv Active-Category of Service Missing
84	Conv Active-Specialty Missing
85	Conv Active-Rate Schedule Missing
86	Conv Active-Affiliation Missing
88	Provider Left Group
90	License Not Active
91	CMS Sanction
92	Provider Type/Service Not Covered
93	Out of State
94	QMB Only-No Medicare Number
95	For Cause
97	Historical Active-Old MMIS System
98	Registration denied
99	Suspension-OIG

### 3.2.4 Provider Type Codes

Provider Type Code	Description	NPI Required?
A7	RESPITE (FOR MQD USE ONLY)	N
BC	Board Certified Behavior Analyst	Y
C1	Acupuncturist	N
C2	Federally Qualified Health Center (FQHC)	Y
C3	Family Planning Services	Y
D1	Dentist – Endodontist	Y
D2	Dentist – Pedodontist	Y
D3	Dentist – Oral Surgeon	Y
D4	Clinic – Dental Services	Y
H1	DD/ID (FOR MQD USE ONLY)	N
S1	SPECIALIZED SERVICES (FOR MQD USE ONLY)	N
Z1	Out-Of-State Middle-Risk Managed Care Only	Y
01	Group-Payment ID (FOR MQD USE ONLY)	N
02	Hospital	Y
03	Pharmacy	Y
04	Laboratory	Y
05	Clinic	Y
06	Emergency Transportation	Y
07	Dentist	Y
08	MD – Physician	Y
09	Certified Nurse – Midwife (FOR MQD USE ONLY)	Y
10	Podiatrist	Y
11	Psychologist	Y
12	Certified Registered Nurse Anesthetist	Y
13	Occupational Therapist	Y
14	Physical Therapist	Y
15	Speech/Hearing Therapist	Y
16	Chiropractor	Y
17	Naturopath	Y
18	Physicians Assistant	Y
19	Registered Nurse Practitioner	Y
20	Respiratory Therapist	Y
21	Massage Therapist	N
22	Nursing Home	Y
23	Home Health Agency	Y
24	Personal Care Attendant	N
27	Adult Day Health	N
28	Non-Emergency Transportation Providers	N

Hawaii PMMIS  
Hawaii Prepaid Medical Management Information System  
Technical Guide - Provider

Provider Type Code	Description	NPI Required?
29	Community/Rural Health Center	Y
30	DME Supplier	Y
31	DO-Physician Osteopath	Y
33	Rehabilitation Center	Y
34	Case Management Services	N
35	Hospice	Y
36	Assisted Living Home/HCBS	N
41	Dialysis Clinic	Y
43	Ambulatory Surgical Center	Y
46	Nurse (Private – RN/LPN)	Y
47	Registered Dietician	N
48	Nutritionist	N
49	Assisted Living Center – Units Only	N
50	Adult Foster Care	N
51	Behavioral Health Counselor	N
52	Mental Health Clinic	N
55	Hotels	N
56	Boarding Home	N
57	Residential Treatment Facility	N
62	Audiologist	Y
63	Drug And Alcohol Rehab	Y
64	Detox Center	Y
69	Optometrist	Y
70	Home Delivered Meals	N
73	Default Provider (FOR MQD USE ONLY)	N
75	MHS Social Worker	N
77	Mental Health Rehabilitation (FOR MQD USE ONLY)	N
78	Mental Health Residential Treatment Center (FOR MQD USE ONLY)	Y
79	Vision Center	Y
80	DHS MHS PROVIDER (FOR MQD USE ONLY)	N
86	Certified Marriage/Family Therapist (CMFT)	Y
90	QMB Only Provider (FOR MQD USE ONLY)	N
91	QMB Only Recipient (FOR MQD USE ONLY)	N
95	Interpreter Services	N
96	Non-Emergency Transportation (Recip)	N
97	Air Transportation	N
98	Case Manager	Y
99	EVS/Non-Service Provider (FOR MQD USE ONLY)	N

### 3.2.5 Provider Specialty Codes

Specialty Code	Description
PCP	PCP Specialty Rates
010	Allergist/Immunologist
011	Allergist
012	Immunologist
015	Optician
019	Geneticist
020	Anesthesiologist
030	Surgery – Colon/Rectal
040	Dermatologist
050	Family Practice
055	General Practice
060	Internal Medicine
062	Cardiovascular Medicine
063	Endocrinologist
064	Gastroenterologist
065	Hematologist
066	Infectious Diseases
067	Nephrologist
068	Pulmonary Diseases
069	Rheumatologist
070	Surgery – Neurology
071	MSW Social Worker
072	Other Microbiology
073	Other Immunohematology
074	Histopathology
075	Neurologist
076	Pediatric Neurologist
077	Homeopathic
078	Clinical Cardiac Electrophysiology
080	Nuclear Medicine
081	Nuclear Physics
082	Gerontologist
083	Psychologist
084	RN – Family Nurse Practitioner
085	RN – School Nurse Practitioner
086	RN – Pediatric Nurse Associate
087	RN – Pediatric Nurse Practitioner
088	RN – Geriatric Nurse Practitioner
089	Obstetrician And Gynecologist
090	Gynecologist
091	Obstetrician
092	Maternal and Fetal Medicine
093	Reproductive Endocrinologist
094	RN – Midwife
095	Women's HC/OB-Gyn Nurse Practitioner

Hawaii PMMIS  
Hawaii Prepaid Medical Management Information System  
Technical Guide - Provider

Specialty Code	Description
096	Neonatal Nurse Practitioner
097	RN – Adult Nurse Practitioner
098	Psych/Mental Health Nurse Practitioner
099	Neurodevelopmental Disabilities
100	Ophthalmology
101	Transplant Hepatology
110	Surgery – Orthopedic
120	Otolaryngologist
122	Laryngologist
124	Otologist
125	Rhinologist
131	Blood Banking
135	Anatomical/Clinical Pathology
136	Forensic Pathology
138	Medical Chemistry
141	Neuropathology
143	Dermatopathology
150	Pediatrician
151	Pediatric – Cardiologist
152	Pediatric – Hematologist
153	Surgery – Pediatric
154	Pediatric – Nephrologist
155	Pediatric – Neonatal/Prenatal Medicine
156	Pediatric – Endocrinologist
157	Pediatric – Allergist
158	Radiology Pediatric
159	Pediatric Pulmonary Disease
160	Physical Medicine/Rehabilitation
161	Osteopathic Manipulative Therapy
162	Sports Medicine
165	Therapist – Speech
166	Therapist – Occupational
167	Therapist – Physical
170	Surgery – Plastic
171	Surgery – Plastic Otolaryngological Facial
175	Acupuncturist
176	Adolescent Medicine
178	Hypnotist
180	Administrative Medicine
181	Surgery – Obstetrical
182	Preventive Medicine
183	Occupational Medicine
184	Public Health
185	Aerospace Medicine
187	Nutritionist
188	Pharmacologist
189	Psychosomatic Medicine

Hawaii PMMIS  
Hawaii Prepaid Medical Management Information System  
Technical Guide - Provider

Specialty Code	Description
191	Pediatric – Psychiatrist
192	Psychiatrist
195	Psychiatrist And Neurologist
200	Radiology
201	Radiology – Diagnostic
205	Radiology – Therapeutic
210	Surgery
211	Surgery – Abdominal
212	Surgery – Cardiovascular
213	Surgery – Hand
214	Surgery – Head And Neck
215	Surgery – Maxillofacial
216	Surgery – Trauma
217	Surgery – Urological
218	Surgery – Vascular
219	Surgery – Gynecological
220	Surgery – Thoracic
230	Urologist
241	Oncologist
250	Emergency Medicine
251	Critical Care Medicine
400	Microbiology
410	Bacteriology
430	Serology
431	Syphilis
437	Other Serology
440	Virology
441	Surgery – Ophthalmological
450	Mycology
460	Parasitology
464	Blood Grouping/Rh Typing
470	Pregnancy Testing
484	Surgery – Podiatrist
490	Immunohematology
500	Rh Titers
501	Crossmatching
503	Physiological Testing
504	EKG Services
510	Clinical Chemistry
511	Routine Chemistry
524	Urinalysis
530	Pathology
532	Oral Pathology
540	Exfoliative Cytology
550	Radiobioassay
574	Histocompatibility
585	Other Clinical Chemistry

Hawaii PMMIS  
Hawaii Prepaid Medical Management Information System  
Technical Guide - Provider

Specialty Code	Description
600	Optometrist
620	Hospice and Palliative Medicine
622	Pediatric Emergency Medicine
650	Podiatrist
714	Eye – Low Vision Specialist
798	Physician Assistant
799	No Specialty Required
800	Dentist – General
801	Dentist – Orthodonture
802	Dentist – Endodontist
803	Dentist – Oral Pathologist
804	Dentist – Pedodontist
805	Dentist – Prosthodontist
806	Dentist – Periodontist
807	Dentist – Public Health
808	Dentist – Oral Surgeon
809	Dentist – Anesthesiologist
880	Developmental Behavioral Pediatrics
900	Procedures – Any Certified Laboratory
901	Emergency Room Physicians
913	Dialysis
925	Audiologist
927	Cardiologist
935	Otorhinolaryngologist (ENT)
943	Pediatric Orthopedist
950	Orthopedist
951	Addiction Medicine
952	Anatomic Pathology
953	Broncho – Esophagology
954	Chemical Dependency
955	Chemical Pathology
956	Diabetes
957	Diagnostic Laboratory Immunology
958	Gynecological Oncology
959	Immunopathology
960	Legal Medicine
961	Neoplastic Diseases
962	Nuclear Radiology
963	Pediatric Hematology – Oncology
964	Pain Control
965	Psychoanalysis
966	Retired
967	Pathology – Radioisotopic
968	Radiology – Oncology
969	Medical Toxicology
970	Hematology and Oncology
971	Industrial Medicine

Hawaii PMMIS  
Hawaii Prepaid Medical Management Information System  
Technical Guide - Provider

Specialty Code	Description
972	Osteopathic Manipulative Medicine
973	Proctology
974	Rehabilitation Medicine
975	Roentgenology (Diagnostic)
976	Sclerotherapy
977	Surgery, Oral and Maxillofacial
999	Other

### 3.2.6 Reimbursement Types

Code	Description
04	Managed Care Only Provider
05	Fee for Service and Managed Care Provider
06	H&CBS, Fee for Service, & Managed Care
07	H&CBS and Managed Care Provider
10	Group PR, Payable Cannot be Service Provider
98	Case Manager, Not Reimbursed
99	Not Reimbursed-Non-Service Provider

### 3.2.7 Provider Types Requiring Ownership/Personnel Data

Provider Type	Description
A7	RESPITE
C2	FEDERALLY QUALIFIED HEALTH CENTER (FQHC)
D4	CLINIC - DENTAL SERVICES
H1	DD/MR
Z1	OUT OF STATE MIDDLE RISK MANAGEMENT CARE
Z2	OUT OF STATE HIGH RISK MANAGEMENT CARE
02	HOSPITAL
03	PHARMACY
04	LABORATORY
05	CLINIC
06	EMERGENCY TRANSPORTATION
22	NURSING HOME
23	HOME HEALTH AGENCY
24	PERSONAL CARE ATTENDANT
27	ADULT DAY HEALTH
28	NON-EMERGENCY TRANSPORTATION PROVIDERS
29	COMMUNITY/RURAL HEALTH CENTER



Hawaii PMMIS  
Hawaii Prepaid Medical Management Information System  
Technical Guide - Provider

30	DME SUPPLIER
33	REHABILITATION CENTER
34	CASE MANAGEMENT SERVICES
35	HOSPICE
36	ASSISTED LIVING HOME (FORMERLY ACH)
41	DIALYSIS CLINIC
43	AMBULATORY SURGICAL CENTER
46	NURSE (PRIVATE-RN/LPN)
49	ASSISTED LIVING CENTER
50	ADULT FOSTER CARE
52	MENTAL HEALTH CLINIC
55	HOTELS
56	BOARDING HOME
57	RESIDENTIAL TREATMENT FACILITY
63	DRUG AND ALCOHOL REHAB
64	DETOX CENTER
70	HOME DELIVERED MEALS
73	DEFAULT PROVIDER
77	BH OUTPATIENT CLINIC
78	MENTAL HEALTH RESIDENTIAL TREATMENT CNTR
79	VISION CENTER
80	DHS MHS PROVIDER
90	QMB ONLY PROVIDER
95	INTERPRETER SERVICES
97	AIR TRANSPORTATION

3.2.8 Title Codes – In Hierarchy Order (for NN record only)

Code	Description
OC	OWNER / COMPANY
OI	OWNER / INDIVIDUAL
CE	CHIEF EXECUTIVE OFFICER
CF	CHIEF FINANCIAL OFFICER
CI	CHIEF INFORMATION OFFICER
CO	CHIEF OPERATING OFFICER
BD	BOARD OF DIRECTORS
MG	MANAGING EMPLOYEE
EM	EMPLOYEE
CN	CONTRACTOR

3.2.9 Criminal Offense Codes (for NN record only)

Code	Description
CON	CONVICTED
DBR	DEBARRED
SUS	SUSPENDED

### 3.2.10 Language Codes

Language Code	Description
AF	Afrikaans
AL	Albanian
AE	Aleut-Eskimo Languages
AI	American Indian
AM	Amharic
AP	Apache
AR	Arabic
AN	Armenian
OA	Asian, Other
BA	Bantu
BE	Bengali
BI	Bisayan
BU	Bulgarian
BR	Burmese
CJ	Cajun
CA	Cambodian
CC	Cantonese
CE	Cebuano
CH	Chamorro
CK	Cherokee
CI	Chinese
CU	Chuukese
CO	Croatian
CS	Cushite
CZ	Czech
DK	Dakota
DA	Danish
DU	Dutch
EN	English
ES	Estonian
FO	Filipino, Other
FN	Finnish
FM	Formosan
FR	French
FC	French Creole
FJ	Fujian

Hawaii PMMIS  
Hawaii Prepaid Medical Management Information System  
Technical Guide - Provider

Language Code	Description
FU	Fulani
GE	German
GR	Greek
GN	Guarani
GU	Gujarati
HA	Hawaiian
HE	Hebrew
HI	Hindi
HM	Hmong
HU	Hungarian
IB	Igbo
FI	Ilocano
ID	India N.E.C.*
OI	Indo-European, Other
IN	Indonesian
IR	Irish
IG	Irish Gaelic
IT	Italian
JM	Jamaican Creole
JA	Japanese
KA	Kannada
KE	Keres
KO	Korean
KS	Kosraean
KH	Kru
KU	Kurdish
LA	Laotian
LT	Latvian
LI	Lithuanian
MC	Macedonian
MA	Malay
MY	Malayalam
ML	Maltese
CM	Mandarin
MD	Mande
MO	Maori
MT	Marathi
MR	Marquesan
MS	Marshallese
MI	Miao-yao, Mien
MK	Mon-Khmer
NA	Navajo
NE	Nepali

Hawaii PMMIS  
Hawaii Prepaid Medical Management Information System  
Technical Guide - Provider

Language Code	Description
ON	North America Indian, Other
NO	Norwegian
OT	Other
AG	Other Alogonquin Language
AO	Other Specified African Language
IO	Other Specified North American Indian
PW	Paiwan
PK	Pakistan N.E.C.*
PA	Palauan
PJ	Panjabi
PP	Papuan
PS	Pashto
PT	Patois
PD	Pennsylvania Dutch
PE	Persian
PO	Pohnpeian
PL	Polish
PR	Portuguese
RA	Rapanui
RO	Romanian
RU	Russian
SA	Samoan
SB	Sebuano
SE	Serbian
SC	Serbocroatian
SI	Sign Language
SN	Sinhalese
SL	Slovak
SV	Slovenian
IL	South/Central American Indian
SO	South Pacific, Other
SP	Spanish
SH	Swahili
SW	Swedish
SY	Syriac
FT	Tagalog
TA	Tahitian
TM	Tamil

Hawaii PMMIS  
Hawaii Prepaid Medical Management Information System  
Technical Guide - Provider

Language Code	Description
TL	Telugu
TH	Thai
TO	Tongan
TU	Turkish
UK	Ukrainian
UN	Unknown
UR	Urdu
VI	Vietnamese
VS	Visayan
YA	Yapese
YI	Yiddish
YO	Yoruba
ZU	Zuni

### 3.3 Appendix 3C – Provider Error Report

#### 3.3.1 File Header Record Format (Provider Error Report)

#	Data Name	Size	Type	Remarks
1	Health Plan ID	6	AN	Health Plan ID
2	Current Date	8	N	CCYYMMDD
3	File Type Code	2	AN	EN = Encounter; PN = Provider Network

#### 3.3.2 Provider Detail Error Report Record Format

#	Data Name	Size	Type	Actual Position		Remarks
				From	To	
1	Row Number	6	N	1	6	File sequence number
2	Health Plan ID	6	A	7	12	Health plan ID
3	Health Plan Provider ID	12	AN	13	24	Health plan assigned provider ID
4	Field ID	5	AN	25	29	Technical Guide item ID
5	Field Description	25	A	30	54	H item Name
6	Error Code	5	N	55	59	Augmented National Provider System error codes
7	Error Message	50	A	60	109	Description of error
8	Field Value	25	AN	110	134	Left justified field value
9	Exclusion Flag	1	YN	135	135	Excluded from assignment

### 3.3.3 File Trailer Record Format (Provider Error Report)

#	Data Name	Size	Type	Remarks
1	Trailer Indicator	6	AN	ZZZZZZ
2	Current Date	8	N	CCYYMMDD
3	Total Count	6	N	Total number of records (including header and trailer records)

## 3.4 Appendix 3D – Provider Health Plan Submission (HPS) and Provider Master Registry (PMR) Record Index/Data Elements

### 3.4.1 Record Type

Characteristics:	ID [ ALL - 1 ]      Type [ AN ]      Length [ 2 ]																										
Record Type:	AA [ X ] BB [ X ] CC [ X ] DD [ X ] EE [ X ] FF [ X ] GG [ X ] HH [ X ] *II [ X ] *JJ [ X ] *KK [ X ] **LL [ X ]																										
Field Status:	Required [ Y ]																										
Field Definition:	Indicates provider record type.																										
Edit Rules/Criteria:	<p>Must not be null.  Must be a valid value.  * "II", "JJ", "KK" Records will be returned on the PMR only.  ** "LL" record will be for the HPS file only.</p> <table style="width: 100%; border: none;"> <thead> <tr> <th style="text-align: left;">Examples:</th> <th style="text-align: left;">Enter As:</th> </tr> </thead> <tbody> <tr> <td>Master Record</td> <td>AA</td> </tr> <tr> <td>Address Record</td> <td>BB</td> </tr> <tr> <td>Group Record</td> <td>CC</td> </tr> <tr> <td>Specialty Record</td> <td>DD</td> </tr> <tr> <td>EPSDT Record</td> <td>EE</td> </tr> <tr> <td>License Record</td> <td>FF</td> </tr> <tr> <td>Contract Record</td> <td>GG</td> </tr> <tr> <td>CLIA Record</td> <td>HH</td> </tr> <tr> <td>Reimbursement Type Record</td> <td>II</td> </tr> <tr> <td>Enrollment Record</td> <td>JJ</td> </tr> <tr> <td>NPI Record</td> <td>KK</td> </tr> <tr> <td>Membership Record</td> <td>LL</td> </tr> </tbody> </table>	Examples:	Enter As:	Master Record	AA	Address Record	BB	Group Record	CC	Specialty Record	DD	EPSDT Record	EE	License Record	FF	Contract Record	GG	CLIA Record	HH	Reimbursement Type Record	II	Enrollment Record	JJ	NPI Record	KK	Membership Record	LL
Examples:	Enter As:																										
Master Record	AA																										
Address Record	BB																										
Group Record	CC																										
Specialty Record	DD																										
EPSDT Record	EE																										
License Record	FF																										
Contract Record	GG																										
CLIA Record	HH																										
Reimbursement Type Record	II																										
Enrollment Record	JJ																										
NPI Record	KK																										
Membership Record	LL																										

### 3.4.2 Health Plan ID

<p>Characteristics:</p> <p>Record Type:</p> <p>Field Status:</p>	<p>ID [ ALL - 2 ]            Type [ AN ]            Length [ 6 ]</p> <p>AA [ X ] BB [ X ] CC [ X ] DD [ X ] EE [ X ] FF [ X ] GG [ X ] HH [ X ] *II [ X ]  *JJ [ X ] *KK [ X ] **LL [ X ]</p> <p>Required [ Y ]</p>
<p>Field Definition:</p>	<p>Indicates submitting health plan. Unique Health Plan ID assigned by DHS Med-QUEST.</p>
<p>Edit Rules/Criteria:</p>	<p>Must not be null.  Must be a valid value.  This field will be populated with "HPMMIS" on the PMR.  * "II", "JJ", "KK" Records will be returned on the PMR only.  **"LL" Record will be for the HPS file only.  Refer to Appendix 3I – Health Plan IDs.</p>

### 3.4.3 Health Plan Provider ID

Characteristics:	ID [ ALL - 3 ]      Type [ AN ]      Length [ 12 ]
Record Type:	AA [ X ] BB [ X ] CC [ X ] DD [ X ] EE [ X ] FF [ X ] GG [ X ] HH [ X ] *II [ X ] *JJ [ X ] *KK [ X ] **LL [ X ]
Field Status:	Required [ Y ]
Field Definition:	Health Plan assigned Provider ID.
Edit Rules/Criteria:	Must not be null. This ID will not be returned on the PMR. * "II", "JJ", "KK" Records will be returned on the PMR only. **"LL" Record will be for the HPS file only.

### 3.4.4 QUEST Provider ID

Characteristics:	ID [ ALL - 4 ]      Type [ AN ]      Length [ 6 ]
Record Type:	AA [ X ] BB [ X ] CC [ X ] DD [ X ] EE [ X ] FF [ X ] GG [ X ] HH [ X ] *II [ X ] *JJ [ X ] *KK [ X ] **LL [ X ]
Field Status:	Required [ C ]
Field Definition:	Unique QUEST assigned provider identification number
Edit Rules/Criteria:	If new provider and the provider is not in PMR, fill with blanks. If not a new provider use valid Quest Provider ID assigned by MQD (PMR). * "II", "JJ", "KK" Records will be returned on the PMR only. **"LL" Record will be for the HPS file only.

### 3.4.5 Name

Characteristics:	ID [ AA - 6 ]      Type [ AN ]      Length [ 40 ]
Record Type:	AA [ X ] BB [ ] CC [ ] DD [ ] EE [ ] FF [ ] GG [ ] HH [ ] II [ ] JJ [ ] KK [ ] LL [ ]
Field Status:	Required [ Y ]
Field Definition:	Provider's name.
Edit Rules/Criteria:	Must not be null. Punctuation is allowed. If it is an individual provider use Last Name/First Name M. Example: John M. Smith Enter as:  S M I T H / J O H N   M  If it is an institutional provider use the business name. Example: Hawaiian Physical Therapists Enter as:  H A W A I I A N   P H Y S I C A L   T H E R A P I S T S





### 3.4.9 NPI

Characteristics:	ID [ AA - 10 ]      Type [ AN ]      Length [ 10 ]
Record Type:	AA [ X ] BB [ ] CC [ ] DD [ ] EE [ ] FF [ ] GG [ ] HH [ ] II [ ] JJ [ ] KK [ ] LL [ ]
Field Status:	Required [ C ]
Field Definition:	National Provider Identifier.
Edit Rules/Criteria:	Required if provider type requires a NPI. Refer to Section 3.2.4 – Provider Type Codes. The NPI will be returned in the KK record only on the PMR. This field will contain spaces in the PMR.

### 3.4.10 NPI Begin Date

Characteristics:	ID [ AA - 11 ]      Type [ N ]      Length [ 8 ]
Record Type:	AA [ X ] BB [ ] CC [ ] DD [ ] EE [ ] FF [ ] GG [ ] HH [ ] II [ ] JJ [ ] KK [ ] LL [ ]
Field Status:	Required [ C ]
Field Definition:	NPI Begin Date
Edit Rules/Criteria:	Must be a valid date in CCYYMMDD format. The NPI Begin Date will be returned in the KK record only on the PMR. This field will contain spaces in the PMR.

### 3.4.11 Date of Birth

Characteristics:	ID [ AA - 12 ]      Type [ N ]      Length [ 8 ]
Record Type:	AA [ X ] BB [ ] CC [ ] DD [ ] EE [ ] FF [ ] GG [ ] HH [ ] II [ ] JJ [ ] KK [ ] LL [ ]
Field Status:	Required [ C ]
Field Definition:	Provider's date of birth.
Edit Rules/Criteria:	Must be a valid date in CCYYMMDD format. Required only when an SSN is submitted denoting an individual provider.

### 3.4.12 Gender

Characteristics:	ID [ AA - 13]      Type [ AN ]      Length [ 1 ]
Record Type:	AA [ X ] BB [ ] CC [ ] DD [ ] EE [ ] FF [ ] GG [ ] HH [ ] II [ ] JJ [ ] KK [ ] LL [ ]
Field Status:	Required [ C ]
Field Definition:	Provider's Gender.
Edit Rules/Criteria:	Must be a valid value. Required only when an SSN is submitted denoting an individual provider.

### 3.4.13 Language Code 1

Characteristics:	ID [ AA - 14]      Type [ AN ]      Length [ 2 ]
Record Type:	AA [ X ] BB [ ] CC [ ] DD [ ] EE [ ] FF [ ] GG [ ] HH [ ] II [ ] JJ [ ] KK [ ] LL [ ]
Field Status:	Required [ C ]
Field Definition:	First Non-English Language of Provider
Edit Rules/Criteria:	Must be a valid value. Refer to 3.2.10 Language Codes table.

### 3.4.14 Language Code 2

Characteristics:	ID [ AA - 15]      Type [ AN ]      Length [ 2 ]
Record Type:	AA [ X ] BB [ ] CC [ ] DD [ ] EE [ ] FF [ ] GG [ ] HH [ ] II [ ] JJ [ ] KK [ ] LL [ ]
Field Status:	Required [ C ]
Field Definition:	Second Non-English Language of Provider
Edit Rules/Criteria:	Must be a valid value. Refer to 3.2.10 Language Codes table.

### 3.4.15 Language Code 3

Characteristics:	ID [ AA - 16]            Type [ AN ]            Length [ 2 ]
Record Type:	AA [ X ] BB [ ] CC [ ] DD [ ] EE [ ] FF [ ] GG [ ] HH [ ] II [ ] JJ [ ] KK [ ] LL [ ]
Field Status:	Required [ C ]
Field Definition:	Third Non-English Language of Provider
Edit Rules/Criteria:	Must be a valid value. Refer to 3.2.10 Language Codes table.

### 3.4.16 Language Code 4

Characteristics:	ID [ AA - 17]            Type [ AN ]            Length [ 2 ]
Record Type:	AA [ X ] BB [ ] CC [ ] DD [ ] EE [ ] FF [ ] GG [ ] HH [ ] II [ ] JJ [ ] KK [ ] LL [ ]
Field Status:	Required [ C ]
Field Definition:	Fourth Non-English Language of Provider
Edit Rules/Criteria:	Must be a valid value. Refer to 3.2.10 Language Codes table.

### 3.4.17 Location Code

Characteristics:	ID [ BB – 5 & II-5 & LL-5 ]            Type [ AN ]            Length [ 2 ]
Record Type:	AA [ ] BB [ X ] CC [ ] DD [ ] EE [ ] FF [ ] GG [ ] HH [ ] *II [ X ] JJ [ ] KK [ ] **LL [ X ]
Field Status:	Required [ N ]
Field Definition:	Code identifying the payment or service locations of the provider.
Edit Rules/Criteria:	Submit on the HPS submission for the LL Record only. The code will be returned on the PMR. “II” Record will be returned on the PMR only. **“LL” Record will be for the HPS file only.

### 3.4.18 Address Type

*Note: Address Type BB record set cannot exceed 40 records per Provider.*

Characteristics:	ID [BB – 6 & II - 6] Type [ AN ] Length [ 1 ]
Record Type:	AA [ ] BB [X] CC [ ] DD [ ] EE [ ] FF [ ] GG [ ] HH [ ] *II [X] JJ [ ] KK [ ] LL [ ]
Field Status:	Required [ Y ]
Field Definition:	Code identifying the type of address associated with the provider.
Edit Rules/Criteria:	<p>Must not be null. Must be a valid value. A (C)orrespondence, a (S)ervice address and a (P)ay To address are required for each record set. * "II" Record will be returned on the PMR only.</p> <p>Examples:           Enter As: Correspondence       C Pay To                P Service                S</p>

### 3.4.19 FEIN

Characteristics:	ID [BB – 7] Type [ AN ] Length [ 9 ]
Record Type:	AA [ ] BB [X] CC [ ] DD [ ] EE [ ] FF [ ] GG [ ] HH [ ] II [ ] JJ [ ] KK [ ] LL [ ]
Field Status:	Required [ C ]
Field Definition:	Federal Employer Identification Number.
Edit Rules/Criteria:	<p>Must be completed if Address Type = P. Enter without punctuation</p> <p>Examples:           Enter As: 99-1234567         9 9 1 2 3 4 5 6 7  05-3456789         0 5 3 4 5 6 7 8 9 </p>

### 3.4.20 Mail Indicator

Characteristics:	ID [BB – 8] Type [ AN ] Length [ 1 ]
Record Type:	AA [ ] BB [X] CC [ ] DD [ ] EE [ ] FF [ ] GG [ ] HH [ ] II [ ] JJ [ ] KK [ ] LL [ ]
Field Status:	Required [ C ]
Field Definition:	"Y" or "N" flag.
Edit Rules/Criteria:	<p>Returned only in the PMR. Populated for Pay-to or Service addresses (Addr-Type = 'P' or 'S') only. Indicates whether or not a provider wants to have correspondence sent to their Pay-To and/or Service addresses also. If Addr-Type is 'P' or 'S' and this field is blank, default is 'N'. Will not have an indicator for the Correspondence address (Addr-Type = C) because it is understood that correspondences will be sent to this address.</p>



### 3.4.24 State

Characteristics:	ID [BB - 12 ]      Type [AN ]      Length [ 2 ]
Record Type:	AA [ ] BB [X] CC [ ] DD [ ] EE [ ] FF [ ] GG [ ] HH [ ] II [ ] JJ [ ] KK [ ] LL [ ]
Field Status:	Required [ Y ]
Field Definition:	State in which the address is located. U.S. Postal Service standard abbreviation.
Edit Rules/Criteria:	Must not be null. Standard abbreviation.  Examples:      Enter As: Hawaii             H I  California         C A

### 3.4.25 Zip Code

Characteristics:	ID [BB – 13 ]      Type [ N ]      Length [ 9 ]
Record Type:	AA [ ] BB [X] CC [ ] DD [ ] EE [ ] FF [ ] GG [ ] HH [ ] II [ ] JJ [ ] KK [ ] LL [ ]
Field Status:	Required [ Y ]
Field Definition:	United States Postal Service standard zip code.
Edit Rules/Criteria:	Must not be null. No punctuation marks. 3.      The +4 is not required – fill with spaces  Example:      339 Kamehameha Street Honolulu, HI 96809-0339 Enter As:       9 6 8 0 9 0 3 3 9   Example:      1314 King St Honolulu HI 96814 Enter As:       9 6 8 1 4

### 3.4.26 Address Begin Date

Characteristics:	ID [BB – 14 ]      Type [ N ]      Length [ 8 ]
Record Type:	AA [ ] BB [X] CC [ ] DD [ ] EE [ ] FF [ ] GG [ ] HH [ ] II [ ] JJ [ ] KK [ ] LL [ ]
Field Status:	Required [ Y ]
Field Definition:	Effective date of provider's address.
Edit Rules/Criteria:	Must not be null. Must be a valid date in CCYYMMDD format. Must be less than or equal to Address End Date  Examples:              Enter As: March 1, 2002         2 0 0 2 0 3 0 1

### 3.4.27 Address End Date

Characteristics:	ID [BB – 15 ]      Type [ N ]      Length [ 8 ]
Record Type:	AA [ ] BB [X] CC [ ] DD [ ] EE [ ] FF [ ] GG [ ] HH [ ] II [ ] JJ [ ] KK [ ] LL [ ]
Field Status:	Required [ C ]
Field Definition:	Expiration date of provider's address.
Edit Rules/Criteria:	Must be a valid date in CCYYMMDD format. Must greater than or equal to the Address Begin Date.  Examples:              Enter As: April 1, 2002         2 0 0 2 0 4 0 1

### 3.4.28 Health Plan Group ID

Characteristics:	ID [CC – 6 ]      Type [ AN ]      Length [ 12 ]
Record Type:	AA [ ] BB [ ] CC [X] DD [ ] EE [ ] FF [ ] GG [ ] HH [ ] II [ ] JJ [ ] KK [ ] LL [ ]
Field Status:	Required [ Y ]
Field Definition:	Provider ID number assigned by the health plan to a designated group or organization.
Edit Rules/Criteria:	Required only if submitting a CC record. This ID will not be returned on the PMR. Must not be null. Must be a valid Health Plan Provider ID, established by an AA Record. Must be a group or organizational provider, where Provider Type = 01.



### 3.4.29 Group QUEST ID

Characteristics:	ID [CC – 7]      Type [AN]      Length [6]
Record Type:	AA [ ] BB [ ] CC [X] DD [ ] EE [ ] FF [ ] GG [ ] HH [ ] II [ ] JJ [ ] KK [ ] LL [ ]
Field Status:	Required [Y]
Field Definition:	QUEST Provider ID number assigned to designated group or organization.
Edit Rules/Criteria:	Required if Group Provider has been assigned a QUEST Provider ID. Must be a valid QUEST Provider ID number assigned in the group's AA to HH record set.

### 3.4.30 Group Begin Date

Characteristics:	ID [CC – 9]      Type [N]      Length [8]
Record Type:	AA [ ] BB [ ] CC [X] DD [ ] EE [ ] FF [ ] GG [ ] HH [ ] II [ ] JJ [ ] KK [ ] LL [ ]
Field Status:	Required [Y]
Field Definition:	Effective Begin Date of the provider's association with the group.
Edit Rules/Criteria:	Required only if submitting a CC record. Must not be null. Must be a valid date in CCYYMMDD format. Must be less than or equal to Group End Date  Examples:      Enter As: March 1, 2002       2 0 0 2 0 3 0 1

### 3.4.31 Group End Date

Characteristics:	ID [CC – 10]      Type [N]      Length [8]
Record Type:	AA [ ] BB [ ] CC [X] DD [ ] EE [ ] FF [ ] GG [ ] HH [ ] II [ ] JJ [ ] KK [ ] LL [ ]
Field Status:	Required [C]
Field Definition:	The date on which the provider became disassociated with the group.
Edit Rules/Criteria:	Must be a valid date in the format CCYYMMDD. Must be greater than or equal to Group Begin Date.  Examples:      Enter As: April 1, 2002       2 0 0 2 0 4 0 1

### 3.4.32 Primary Indicator

Characteristics:	ID [DD – 6 ]      Type [ AN ]      Length [ 1 ]
Record Type:	AA [ ] BB [ ] CC [ ] DD [X] EE [ ] FF [ ] GG [ ] HH [ ] II [ ] JJ [ ] KK [ ] LL [ ]
Field Status:	Required [ Y ]
Field Definition:	Indicator used to designate the specialty identified on this specific record is primary to the provider.
Edit Rules/Criteria:	Required only if submitting a DD record. Must not be null. Must be a valid value, Y(es) or N(o). Only one active primary specialty per provider in a given time period.

### 3.4.33 Specialty Code

Characteristics:	ID [ DD – 7 ]      Type [ AN ]      Length [ 3 ]
Record Type:	AA [ ] BB [ ] CC [ ] DD [X] EE [ ] FF [ ] GG [ ] HH [ ] II [ ] JJ [ ] KK [ ] LL [ ]
Field Status:	Required [ Y ]
Field Definition:	Code classifying the provider by specialty, as associated with the health plan..
Edit Rules/Criteria:	Required only if submitting a DD record. Must not be null. Must be a valid value. Refer to Appendix 3B – Provider Codes and Values sub-section 3.2.5 Provider Specialty Codes  Examples:                      Enter As: Anesthesiologist               0 2 0  Surgery – Maxillofacial       2 1 5   Submit only <u>Board Certified</u> specialties. Please <u>do not</u> submit a Board Eligible specialty.

### 3.4.34 Specialty Begin Date

Characteristics:	ID [ DD – 8 ]      Type [ N ]      Length [ 8 ]
Record Type:	AA [ ] BB [ ] CC [ ] DD [X] EE [ ] FF [ ] GG [ ] HH [ ] II [ ] JJ [ ] KK [ ] LL [ ]
Field Status:	Required [ Y ]
Field Definition:	Effective date of the provider’s specialty within the health plan.
Edit Rules/Criteria:	Required only if submitting a DD record. Must not be null. Must be a valid date in the format CCYYMMDD. Must be less than or equal to Specialty End Date.  Examples:                      Enter As: March 1, 2002       2 0 0 2 0 3 0 1

### 3.4.35 Specialty End Date

Characteristics:	ID [ DD – 9 ]      Type [ N ]      Length [ 8 ]
Record Type:	AA [ ] BB [ ] CC [ ] DD [ X ] EE [ ] FF [ ] GG [ ] HH [ ] II [ ] JJ [ ] KK [ ] LL [ ]
Field Status:	Required [ C ]
Field Definition:	Expiration date of the provider’s specialty within the health plan.
Edit Rules/Criteria:	Must be a valid date in the format CCYYMMDD. Must be greater than or equal to Specialty Begin Date.  Examples:      Enter As: April 1, 2002     2 0 0 2 0 4 0 1

### 3.4.36 PCP Indicator

Characteristics:	ID [ DD – 10 ]      Type [ AN ]      Length [ 1 ]
Record Type:	AA [ ] BB [ ] CC [ ] DD [ X ] EE [ ] FF [ ] GG [ ] HH [ ] II [ ] JJ [ ] KK [ ] LL [ ]
Field Status:	Required [ Y ]
Field Definition:	Indicates that the provider has been designated as a primary care provider within the health plan.
Edit Rules/Criteria:	Required only if submitting a DD record. Must not be null. Must be a valid value, Y(es) or N(o). A value of Y is valid for the following specialties: Family Practice                      OB-GYN General Practice                      Certified Nurse Mid-Wife Internal Medicine                      General or Family Nurse Practitioner Pediatrics                                  Pediatric Nurse Practitioner Not returned on the PMR.

### 3.4.37 PCP Specialty Indicator (PMR File Only)

Characteristics:	ID [ DD – 11 ]      Type [ AN ]      Length [ 1 ]
Record Type:	AA [ ] BB [ ] CC [ ] DD [ X ] EE [ ] FF [ ] GG [ ] HH [ ] II [ ] JJ [ ] KK [ ] LL [ ]
Field Status:	Required [ N ]
Field Definition:	Self-Attestation Value.
Edit Rules/Criteria:	Do not submit this record on the HPS submission. Will contain one of the following values: B = Board Certified 6 = 60% Criteria Met N = Not Attested 7 = 60% criteria, new provider

### 3.4.38 Attestation Date (PMR File Only)

Characteristics:	ID [ DD – 12 ]      Type [ N ]      Length [ 8 ]
Record Type:	AA [ ] BB [ ] CC [ ] DD [ X ] EE [ ] FF [ ] GG [ ] HH [ ] II [ ] JJ [ ] KK [ ] LL [ ]
Field Status:	Required [ N ]
Field Definition:	Indicates date of Self Attestation.
Edit Rules/Criteria:	Do not submit this record on the HPS submission.

### 3.4.39 EPSDT Begin Date

Characteristics:	ID [ EE – 6 ]      Type [ N ]      Length [ 8 ]
Record Type:	AA [ ] BB [ ] CC [ ] DD [ ] EE [ X ] FF [ ] GG [ ] HH [ ] II [ ] JJ [ ] KK [ ] LL [ ]
Field Status:	Required [ Y ]
Field Definition:	Date on which the provider was certified to perform EPSDT services within the health plan.
Edit Rules/Criteria:	Required only if submitting a EE record. Must not be null. Must be a valid date in the format CCYYMMDD. Must be less than or equal to EPSDT End Date.  Examples:              Enter As: March 1, 2002         2 0 0 2 0 3 0 1

### 3.4.40 EPSDT End Date

Characteristics:	ID [ EE – 7 ]      Type [ N ]      Length [ 8 ]
Record Type:	AA [ ] BB [ ] CC [ ] DD [ ] EE [ X ] FF [ ] GG [ ] HH [ ] II [ ] JJ [ ] KK [ ] LL [ ]
Field Status:	Required [ C ]
Field Definition:	Date on which the provider was decertified to perform EPSDT services within the health plan.
Edit Rules/Criteria:	Must be a valid date in the format CCYYMMDD. Must be greater than or equal to EPSDT Begin Date.  Examples:              Enter As: April 1, 2002         2 0 0 2 0 4 0 1

### 3.4.41 Agency ID

Characteristics:	ID [ FF – 6 ]	Type [ AN ]	Length [ 3 ]
Record Type:	AA [ ] BB [ ] CC [ ] DD [ ] EE [ ] FF [X] GG [ ] HH [ ] II [ ] JJ [ ] KK [ ] LL [ ]		
Field Status:	Required [ Y ]		
Field Definition:	Code identifies the licensing agency or board.		
Edit Rules/Criteria:	<p>Required only if submitting a FF record.  Must not be null.  Must be valid value. Refer to Appendix 3B – Provider Codes and Values.</p> <p>Examples:                      Enter As:  Drug Enforcement Agency     0 1 7   Board of Medical Examiners     3 2 0 </p>		

### 3.4.42 DEA Level

Characteristics:	ID [ FF – 7 ]	Type [ AN ]	Length [ 1 ]
Record Type:	AA [ ] BB [ ] CC [ ] DD [ ] EE [ ] FF [X] GG [ ] HH [ ] II [ ] JJ [ ] KK [ ] LL [ ]		
Field Status:	Required [ C ]		
Field Definition:	Qualifies the DEA license number.		
Edit Rules/Criteria:	<p>Not required for Agency Code 017.  Must be a valid value.</p>		

### 3.4.43 License/Certificate Number

Characteristics:	ID [ FF – 8 ]	Type [ AN ]	Length [ 15 ]
Record Type:	AA [ ] BB [ ] CC [ ] DD [ ] EE [ ] FF [X] GG [ ] HH [ ] II [ ] JJ [ ] KK [ ] LL [ ]		
Field Status:	Required [ Y ]		
Field Definition:	License number assigned to a provider.		
Edit Rules/Criteria:	<p>Required only if submitting a FF record.  Must not be null.  Must be a valid license/certificate number.  License/Certificate type is left justified.  License/Certificate number is right justified with leading zeros.  License Type and License number are combined to fill 15 position fields.  No punctuation. Refer to Appendix 3B – Provider Codes and Values sub-section 3.2.2 License Type Codes.</p> <p>Examples:                      Enter As:  MD-0000001                       M D 0 0 0 0 0 0 0 0 0 0 0 0 1   RN 235                               R N 0 0 0 0 0 0 0 0 0 0 0 2 3 5   DDS004563                         D D S 0 0 0 0 0 0 0 0 0 4 5 6 3 </p>		

### 3.4.44 License/Certification Begin Date

Characteristics:	ID [ FF – 9 ]      Type [ N ]      Length [ 8 ]
Record Type:	AA [ ] BB [ ] CC [ ] DD [ ] EE [ ] FF [ X ] GG [ ] HH [ ] II [ ] JJ [ ] KK [ ] LL [ ]
Field Status:	Required [ Y ]
Field Definition:	Effective date of the provider’s license.
Edit Rules/Criteria:	Required only if submitting a FF record. Must not be null. Must be a valid date in the format CCYYMMDD. Must be less than or equal to License Expiration Date  Examples:            Enter As: March 1, 2002       2 0 0 2 0 3 0 1

### 3.4.45 License/Certification Expiration Date

Characteristics:	ID [ FF – 10 ]      Type [ N ]      Length [ 8 ]
Record Type:	AA [ ] BB [ ] CC [ ] DD [ ] EE [ ] FF [ X ] GG [ ] HH [ ] II [ ] JJ [ ] KK [ ] LL [ ]
Field Status:	Required [ C ]
Field Definition:	Termination date of the provider’s license.
Edit Rules/Criteria:	Must be a valid date in the format CCYYMMDD. Must be greater than or equal to License Begin Date.  Examples:            Enter As: April 1, 2002       2 0 0 2 0 4 0 1

### 3.4.46 Contract Begin Date

Characteristics:	ID [ GG – 6 ]      Type [ N ]      Length [ 8 ]
Record Type:	AA [ ] BB [ ] CC [ ] DD [ ] EE [ ] FF [ ] GG [ X ] HH [ ] II [ ] JJ [ ] KK [ ] LL [ ]
Field Status:	Required [ Y ]
Field Definition:	Effective date of the health plan’s contract with the provider.
Edit Rules/Criteria:	Required when submitting a GG record Must not be null. Must be a valid date in the format CCYYMMDD. Must be less than or equal to Contract Expiration Date  Examples:            Enter As: March 1, 2002       2 0 0 2 0 3 0 1







California	C A
------------	-----

### 3.4.53 Zip Code

Characteristics:	ID [ H – 11 ]      Type [ N ]      Length [ 9 ]
Record Type:	AA [ ] BB [ ] CC [ ] DD [ ] EE [ ] FF [ ] GG [ ] HH [ X ] II [ ] JJ [ ] KK [ ] LL [ ]
Field Status:	Required [ Y ]
Field Definition:	United States Postal Service standard zip code.
Edit Rules/Criteria:	<p>Required only if submitting an HH record.  Must not be null.  No punctuation marks.  The +4 is not required – fill with spaces</p> <p>Example:      94-3000 Kalaniana'ole Parkway                      Waipahu, HI 96797</p> <p>Enter As:       9 6 7 9 7         </p> <p>Example:      339 Kamehameha Street                      Honolulu, HI 96809-0339</p> <p>Enter As:       9 6 8 0 9 0 3 3 9 </p>

### 3.4.54 CLIA Begin Date

Characteristics:	ID [ HH – 12 ]      Type [ N ]      Length [ 8 ]
Record Type:	AA [ ] BB [ ] CC [ ] DD [ ] EE [ ] FF [ ] GG [ ] HH [ X ] II [ ] JJ [ ] KK [ ] LL [ ]
Field Status:	Required [ Y ]
Field Definition:	Effective date of the provider's CLIA license.
Edit Rules/Criteria:	<p>Required only if submitting a HH record.  Must not be null  Must be a valid date in the format CCYYMMDD.  Must be less than or equal to the CLIA End Date</p> <p>Examples:      Enter As:  March 1, 2002       2 0 0 2 0 3 0 1 </p>

### 3.4.55 CLIA End Date

Characteristics:	ID [ HH – 13 ]	Type [ N ]	Length [ 8 ]
Record Type:	AA [ ] BB [ ] CC [ ] DD [ ] EE [ ] FF [ ] GG [ ] HH [ X ] II [ ] JJ [ ] KK [ ] LL [ ]		
Field Status:	Required [ C ]		
Field Definition:	Termination date of the provider's CLIA number.		
Edit Rules/Criteria:	Must be a valid date in the format CCYYMMDD. Must be greater than or equal to the CLIA BEGIN DATE.		
	Examples:	Enter As:	
	April 1, 2002	[ 2 0 0 2 0 4 0 1 ]	

### 3.4.56 Attention To (PMR file only)

Characteristics:	ID [ II – 7 ]	Type [ AN ]	Length [ 40 ]
Record Type:	AA [ ] BB [ ] CC [ ] DD [ ] EE [ ] FF [ ] GG [ ] HH [ ] II [ X ] JJ [ ] KK [ ] LL [ ]		
Field Status:	Required [ N ]		
Field Definition:	Attention To line of the Provider's Address.		
Edit Rules/Criteria:	Returned only in the PMR file. Free text.		

### 3.4.57 Address Phone (PMR file only)

Characteristics:	ID [ II – 8 ]	Type [ AN ]	Length [ 10 ]
Record Type:	AA [ ] BB [ ] CC [ ] DD [ ] EE [ ] FF [ ] GG [ ] HH [ ] II [ X ] JJ [ ] KK [ ] LL [ ]		
Field Status:	Required [ N ]		
Field Definition:	Business Phone of the Provider.		
Edit Rules/Criteria:	Returned only in the PMR file.		

### 3.4.58 Address Fax (PMR file only)

Characteristics:	ID [ II – 9 ]	Type [ AN ]	Length [ 10 ]
Record Type:	AA [ ] BB [ ] CC [ ] DD [ ] EE [ ] FF [ ] GG [ ] HH [ ] II [ X ] JJ [ ] KK [ ] LL [ ]		
Field Status:	Required [ N ]		
Field Definition:	Fax number of the Provider.		
Edit Rules/Criteria:	Returned only in the PMR file.		

### 3.4.59 Reimbursement Type (PMR file only)

Characteristics:	ID [ II – 10 ]      Type [ AN ]      Length [ 2 ]
Record Type:	AA [ ] BB [ ] CC [ ] DD [ ] EE [ ] FF [ ] GG [ ] HH [ ] II [ X ] JJ [ ] KK [ ] LL [ ]
Field Status:	Required [ N ]
Field Definition:	Provider Reimbursement Type.
Edit Rules/Criteria:	Returned only in the PMR file. Populated only if Address Type = 'C', otherwise will be Space filled.  Valid Values are:  01      Fee For Service 04      Managed Care Only Provider 05      Fee For Service and Managed Care Provider 06      H&CBS, Fee For Service & Managed Care 07      H&CBS and Managed Care Provider 10      Group Provider, Payable Cannot Be Service Provider 98      Case Manager, Not Reimbursed 99      Not Reimbursed-Non-Service Provider

### 3.4.60 Reimbursement Begin Date (PMR file only)

Characteristics:	ID [ II – 11 ]      Type [ AN ]      Length [ 8 ]
Record Type:	AA [ ] BB [ ] CC [ ] DD [ ] EE [ ] FF [ ] GG [ ] HH [ ] II [ X ] JJ [ ] KK [ ] LL [ ]
Field Status:	Required [ N ]
Field Definition:	Provider Begin Date of Reimbursement Type.
Edit Rules/Criteria:	Returned only in the PMR file. Populated only if Address Type = 'C', otherwise will be Space filled. Format CCYYMMDD.

### 3.4.61 Reimbursement End Date (PMR file only)

Characteristics:	ID [ II – 12 ]      Type [ AN ]      Length [ 8 ]
Record Type:	AA [ ] BB [ ] CC [ ] DD [ ] EE [ ] FF [ ] GG [ ] HH [ ] II [ X ] JJ [ ] KK [ ] LL [ ]
Field Status:	Required [ N ]
Field Definition:	Provider End Date of Reimbursement Type.
Edit Rules/Criteria:	Returned only in the PMR file. Populated only if Address Type = 'C', otherwise will be Space filled. Format CCYYMMDD.

### 3.4.62 Provider Status Type (PMR file only)

Characteristics:	ID [ JJ - 5 ]            Type [ AN ]            Length [ 2 ]
Record Type:	AA [ ] BB [ ] CC [ ] DD [ ] EE [ ] FF [ ] GG [ ] HH [ ] II [ ] JJ [ X ] KK [ ] LL [ ]
Field Status:	Required [ N ]
Field Definition:	Provider Status Type.
Edit Rules/Criteria:	Do not submit on the HPS submission. The Provider Status Type will be returned on the PMR only.

### 3.4.63 Provider Status Code (PMR file only)

Characteristics:	ID [ JJ - 6 ]            Type [ AN ]            Length [ 2 ]
Record Type:	AA [ ] BB [ ] CC [ ] DD [ ] EE [ ] FF [ ] GG [ ] HH [ ] II [ ] JJ [ X ] KK [ ] LL [ ]
Field Status:	Required [ N ]
Field Definition:	Provider Status Code.
Edit Rules/Criteria:	Do not submit on the HPS submission. The Provider Status Code will be returned on the PMR only. Refer to Table of Provider Status Codes for list of Status Codes and the definitions.

### 3.4.64 Provider Status Begin Date (PMR file only)

Characteristics:	ID [ JJ - 7 ]            Type [ AN ]            Length [ 8 ]
Record Type:	AA [ ] BB [ ] CC [ ] DD [ ] EE [ ] FF [ ] GG [ ] HH [ ] II [ ] JJ [ X ] KK [ ] LL [ ]
Field Status:	Required [ N ]
Field Definition:	Provider Status Type.
Edit Rules/Criteria:	Do not submit on the HPS submission. The Provider Status Begin Date will be returned on the PMR only.

### 3.4.65 Provider Status End Date (PMR file only)

Characteristics:	ID [ JJ - 8 ]            Type [ AN ]            Length [ 8 ]
Record Type:	AA [ ] BB [ ] CC [ ] DD [ ] EE [ ] FF [ ] GG [ ] HH [ ] II [ ] JJ [ X ] KK [ ] LL [ ]
Field Status:	Required [ N ]
Field Definition:	Provider Status Type.
Edit Rules/Criteria:	Do not submit on the HPS submission. The Provider Status End Date will be returned on the PMR only.

### 3.4.66 Replacement Provider ID (PMR file only)

Characteristics:	ID [ JJ – 9 ]      Type [ AN ]      Length [ 8 ]
Record Type:	AA [ ] BB [ ] CC [ ] DD [ ] EE [ ] FF [ ] GG [ ] HH [ ] II [ ] JJ [ X ] KK [ ] LL [ ]
Field Status:	Required [ N ]
Field Definition:	Replacement Provider ID.
Edit Rules/Criteria:	Do not submit on the HPS submission. The Replacement Provider ID will be returned on the PMR only.

### 3.4.67 NPI (PMR file only)

Characteristics:	ID [ KK – 5 ]      Type [ AN ]      Length [ 10 ]
Record Type:	AA [ ] BB [ ] CC [ ] DD [ ] EE [ ] FF [ ] GG [ ] HH [ ] II [ ] JJ [ ] KK [ X ] LL [ ]
Field Status:	Required [ N ]
Field Definition:	National Provider Identifier.
Edit Rules/Criteria:	Do not submit this record on the HPS submission. The NPI will be returned on the PMR for informational purposes.

### 3.4.68 NPI Begin Date (PMR file only)

Characteristics:	ID [ KK – 6 ]      Type [ AN ]      Length [ 8 ]
Record Type:	AA [ ] BB [ ] CC [ ] DD [ ] EE [ ] FF [ ] GG [ ] HH [ ] II [ ] JJ [ ] KK [ X ] LL [ ]
Field Status:	Required [ N ]
Field Definition:	Effective date of National Provider Identifier.
Edit Rules/Criteria:	Do not submit this record on the HPS submission. This date will be returned on the PMR.

### 3.4.69 NPI End Date (PMR file only)

Characteristics:	ID [ KK – 7 ]      Type [ AN ]      Length [ 8 ]
Record Type:	AA [ ] BB [ ] CC [ ] DD [ ] EE [ ] FF [ ] GG [ ] HH [ ] II [ ] JJ [ ] KK [ X ] LL [ ]
Field Status:	Required [ N ]
Field Definition:	End date of National Provider Identifier.
Edit Rules/Criteria:	Do not submit this record on the HPS submission. This date will be returned on the PMR.

### 3.4.70 Island Code (HPS file only)

Characteristics:	ID [LL – 6]                      Type [ AN ]                      Length [ 2 ]
Record Type:	AA [ ] BB [ ] CC [ ] DD [ ] EE [ ] FF [ ] GG [ ] HH [ ] II [ ] JJ [ ] KK [ ] LL [ X ]
Field Status:	Required [ Y ]
Field Definition:	Code identifying the island where the service occurred.
Edit Rules/Criteria:	Will not be returned on the PMR file.  Valid Values:  01 = Oahu 04 = Kauai 05 = Hawaii 07 = Maui 08 = Molokai 09 = Lanai 31 = Out of State 33 = Out of Country

### 3.4.71 Recipient Count (HPS file only)

Characteristics:	ID [LL – 7]                      Type [ N ]                      Length [ 5 ]
Record Type:	AA [ ] BB [ ] CC [ ] DD [ ] EE [ ] FF [ ] GG [ ] HH [ ] II [ ] JJ [ ] KK [ ] LL [ X ]
Field Status:	Required [ **Y ]
Field Definition:	Number of recipients assigned to this provider.
Edit Rules/Criteria:	**This field should be populated if provider is a pcp. If provider is a pcp, must be right justified and greater than or equal to zero. Will not be returned on the PMR file.

### 3.4.72 Recipient Maximum (HPS file only)

Characteristics:	ID [LL – 8]                      Type [ N ]                      Length [ 5 ]
Record Type:	AA [ ] BB [ ] CC [ ] DD [ ] EE [ ] FF [ ] GG [ ] HH [ ] II [ ] JJ [ ] KK [ ] LL [ X ]
Field Status:	Required [ **Y ]
Field Definition:	Maximum number of recipients that the provider has agreed to accept.
Edit Rules/Criteria:	**This field should be populated if provider is a pcp. If provider is a pcp, must be right justified and greater than or equal to zero. Will not be returned on the PMR file.

### 3.4.73 New Patient Indicator (HPS file only)

Characteristics:	ID [LL – 9]                      Type [ AN ]                      Length [ 1 ]
Record Type:	AA [ ] BB [ ] CC [ ] DD [ ] EE [ ] FF [ ] GG [ ] HH [ ] II [ ] JJ [ ] KK [ ] LL [ X ]
Field Status:	Required [ **Y ]
Field Definition:	“Y” or “N” Indicator.
Edit Rules/Criteria:	**This field should be populated if provider is a pcp. If provider is currently accepting new patient assignments as a pcp, indicator should be ‘Y’. Will not be returned on the PMR file.

### 3.4.74 Credentialing Begin Date (PMR file only)

Characteristics:	ID [MM – 5]                      Type [ N ]                      Length [ 8 ]
Record Type:	AA [ ] BB [ ] CC [ ] DD [ ] EE [ ] FF [ ] GG [ ] HH [ ] II [ ] JJ [ ] KK [ ] LL [ ] MM [ X ]
Field Status:	Required [ Y ]
Field Definition:	Provider Credentialing effective date
Edit Rules/Criteria:	Required only if submitting a MM record. Must not be null. Must be a valid date in the format CCYYMMDD. Must be less than Credentialing End Date if Credentialing Flag = “Y”.

### 3.4.75 Credentialing End Date (PMR file only)

Characteristics:	ID [MM – 6]                      Type [ N ]                      Length [ 8 ]
Record Type:	AA [ ] BB [ ] CC [ ] DD [ ] EE [ ] FF [ ] GG [ ] HH [ ] II [ ] JJ [ ] KK [ ] LL [ ] MM [ X ]
Field Status:	Required [ Y ]
Field Definition:	Date of when provider credentialing will expire.
Edit Rules/Criteria:	Must be a valid date in the format CCYYMMDD. If Credentialing Flag = “Y”, end date must not be null nor have 99999999. If Credentialing Flag = “N”, end date can be populated with 99999999 if no expiration date.

### 3.4.76 Credentialing Flag (PMR file only)

Characteristics:	ID [MM – 7]            Type [ AN ]            Length [ 1 ]
Record Type:	AA [ ] BB [ ] CC [ ] DD [ ] EE [ ] FF [ ] GG [ ] HH [ ] II [ ] JJ [ ] KK [ ] LL [ ] MM [ X ]
Field Status:	Required [ Y ]
Field Definition:	“Y” if credentialing was successful; “N” if not successful.
Edit Rules/Criteria:	Required only if submitting a MM record Must be “Y” or “N”.

### 3.4.77 Submitting Health Plan (PMR file only)

Characteristics:	ID [MM – 8]            Type [ AN ]            Length [ 6 ]
Record Type:	AA [ ] BB [ ] CC [ ] DD [ ] EE [ ] FF [ ] GG [ ] HH [ ] II [ ] JJ [ ] KK [ ] LL [ ] MM [ X ]
Field Status:	Required [ C ]
Field Definition:	6 character Health Plan ID that submitted the credentialed record
Edit Rules/Criteria:	Do not submit. This info will be returned on the PMR.

### 3.4.78 Load Date (PMR file only)

Characteristics:	ID [MM – 9]            Type [ AN ]            Length [ 8 ]
Record Type:	AA [ ] BB [ ] CC [ ] DD [ ] EE [ ] FF [ ] GG [ ] HH [ ] II [ ] JJ [ ] KK [ ] LL [ ] MM [ X ]
Field Status:	Required [ C ]
Field Definition:	Date credentialed record was loaded in HPMMIS.
Edit Rules/Criteria:	Do not submit. This date will be returned on the PMR.



### 3.4.79 Personnel/Company Name (PMR file only)

Characteristics:	ID [NN – 5]            Type [ AN ]            Length [ 25 ]
Record Type:	AA [ ] BB [ ] CC [ ] DD [ ] EE [ ] FF [ ] GG [ ] HH [ ] II [ ] JJ [ ] KK [ ] LL [ ] MM [ ] NN [ X ]
Field Status:	Required [ Y ]
Field Definition:	Personnel Name or Company Name
Edit Rules/Criteria:	Personnel Name format: last name/first name Company Name format: no ‘/’

### 3.4.80 Date of Birth (PMR file only)

Characteristics:	ID [ NN - 6 ]            Type [ N ]            Length [ 8 ]
Record Type:	AA [ ] BB [ ] CC [ ] DD [ ] EE [ ] FF [ ] GG [ ] HH [ ] II [ ] JJ [ ] KK [ ] LL [ ] MM [ ] NN [ X ]
Field Status:	Required [ C ]
Field Definition:	Personnel’s date of birth.
Edit Rules/Criteria:	Must be a valid date in CCYYMMDD format. Required only when an SSN is submitted denoting an individual.  In PMR file, this field will contain spaces.

### 3.4.81 Personnel SSN (PMR file only)

Characteristics:	ID [NN – 7]            Type [ N ]            Length [ 9 ]
Record Type:	AA [ ] BB [ ] CC [ ] DD [ ] EE [ ] FF [ ] GG [ ] HH [ ] II [ ] JJ [ ] KK [ ] LL [ ] MM [ ] NN [ X ]
Field Status:	Required [ C ]
Field Definition:	Number assigned by the Social Security Administration to uniquely identify individuals.
Edit Rules/Criteria:	If Field NN-5 contains a “/”, SSN is required.  No punctuation (hyphens). Examples:     Enter As: 591-62-1111     5 9 1 6 2 1 1 1 1   In PMR file, this field will contain spaces.

### 3.4.82 Taxpayer ID (PMR file only)

Characteristics:	ID [NN - 8]            Type [ N ]            Length [ 9 ]
Record Type:	AA [ ] BB [ ] CC [ ] DD [ ] EE [ ] FF [ ] GG [ ] HH [ ] II [ ] JJ [ ] KK [ ] LL [ ] MM [ ] NN [ X ]
Field Status:	Required [ C ]
Field Definition:	Federal Employer Identification Number.
Edit Rules/Criteria:	If Field NN-5 does not contain a "/", Taxpayer ID is required.  Enter without punctuation Examples:        Enter As: 99-1234567         9 9 1 2 3 4 5 6 7  05-3456789         0 5 3 4 5 6 7 8 9   In PMR file, this field will contain spaces.

### 3.4.83 Title Code (PMR file only)

Characteristics:	ID [ NN - 9]            Type [ AN ]            Length [ 2 ]
Record Type:	AA [ ] BB [ ] CC [ ] DD [ ] EE [ ] FF [ ] GG [ ] HH [ ] II [ ] JJ [ ] KK [ ] LL [ ] MM [ ] NN [ X ]
Field Status:	Required [ Y ]
Field Definition:	Personnel-Ownership Title Codes
Edit Rules/Criteria:	Refer to Section <a href="#">3.2.8</a> for list of codes. If Field NN-5 contains "/", Title Code "OC" cannot be used. If Field NN-5 does not contain "/", Title Code "OC" is required.  In PMR file, this field will contain spaces.

### 3.4.84 Begin Date (PMR file only)

Characteristics:	ID [ NN - 10]            Type [ N ]            Length [ 8 ]
Record Type:	AA [ ] BB [ ] CC [ ] DD [ ] EE [ ] FF [ ] GG [ ] HH [ ] II [ ] JJ [ ] KK [ ] LL [ ] MM [ ] NN [ X ]
Field Status:	Required [ Y ]
Field Definition:	Begin Date of Title position.
Edit Rules/Criteria:	Must be in CCYYMMDD format. May be a future date. Must be a valid date. May not overlap another record with same SSN in same provider group. May not overlap another record with same SSN under same provider in PMR.  In PMR file, this field will contain spaces.

### 3.4.85 End Date (PMR file only)

Characteristics:	ID [ NN - 11 ]      Type [ N ]      Length [ 8 ]
Record Type:	AA [ ] BB [ ] CC [ ] DD [ ] EE [ ] FF [ ] GG [ ] HH [ ] II [ ] JJ [ ] KK [ ] LL [ ] MM [ ] NN [ X ]
Field Status:	Required [ C ]
Field Definition:	End Date of Title position.
Edit Rules/Criteria:	Must be in CCYYMMDD format. If submitted, must be equal to or greater than Begin Date. Default to 99999999 if blank. May not overlap another record with same SSN in same provider group. May not overlap another record with same SSN under same provider in PMR. In PMR file, this field will contain spaces.

### 3.4.86 Criminal Offense Code (PMR file only)

Characteristics:	ID [ NN - 12 ]      Type [ AN ]      Length [ 3 ]
Record Type:	AA [ ] BB [ ] CC [ ] DD [ ] EE [ ] FF [ ] GG [ ] HH [ ] II [ ] JJ [ ] KK [ ] LL [ ] MM [ ] NN [ X ]
Field Status:	Required [ C ]
Field Definition:	Code which describes a criminal offense by the Individual.
Edit Rules/Criteria:	Optional – may be left blank. Value used must be found in the Criminal Offense Table in Section <a href="#">3.2.9</a> .  In PMR file, this field will contain spaces.

### 3.4.87 Street Address#1 (PMR file only)

Characteristics:	ID [ NN - 13 ]      Type [ AN ]      Length [ 55 ]
Record Type:	AA [ ] BB [ ] CC [ ] DD [ ] EE [ ] FF [ ] GG [ ] HH [ ] II [ ] JJ [ ] KK [ ] LL [ ] MM [ ] NN [ X ]
Field Status:	Required [ Y ]
Field Definition:	If Individual, use home street address. If Business, use business address.
Edit Rules/Criteria:	Required if Title Code is not "EM". Free text. Punctuation allowed. Left justified with trailing blanks. Postal Service standards for abbreviations.  In PMR file, this field will contain spaces.

### 3.4.88 Street Address#2 (PMR file only)

Characteristics:	ID [ NN - 14]      Type [ AN ]      Length [ 55 ]
Record Type:	AA [ ] BB [ ] CC [ ] DD [ ] EE [ ] FF [ ] GG [ ] HH [ ] II [ ] JJ [ ] KK [ ] LL [ ] MM [ ] NN [ X ]
Field Status:	Required [ C ]
Field Definition:	Second line of address.
Edit Rules/Criteria:	Optional – may be left blank. Requires Addr#1. Free text. Punctuation allowed. Left justified with trailing blanks. Postal Service standards for abbreviations. In PMR file, this field will contain spaces.

### 3.4.89 City (PMR file only)

Characteristics:	ID [ NN - 15]      Type [ AN ]      Length [ 25 ]
Record Type:	AA [ ] BB [ ] CC [ ] DD [ ] EE [ ] FF [ ] GG [ ] HH [ ] II [ ] JJ [ ] KK [ ] LL [ ] MM [ ] NN [ X ]
Field Status:	Required [ Y ]
Field Definition:	City in which the Address is located.
Edit Rules/Criteria:	Free text. In PMR file, this field will contain spaces.

### 3.4.90 State (PMR file only)

Characteristics:	ID [ NN - 16]      Type [ AN ]      Length [ 2 ]
Record Type:	AA [ ] BB [ ] CC [ ] DD [ ] EE [ ] FF [ ] GG [ ] HH [ ] II [ ] JJ [ ] KK [ ] LL [ ] MM [ ] NN [ X ]
Field Status:	Required [ Y ]
Field Definition:	State in which the Address is located.
Edit Rules/Criteria:	U.S. Postal Service standard abbreviation. In PMR file, this field will contain spaces.

### 3.4.91 Zip Code (PMR file only)

Characteristics:	ID [ NN - 17]      Type [ N]      Length [ 5]
Record Type:	AA [ ] BB [ ] CC [ ] DD [ ] EE [ ] FF [ ] GG [ ] HH [ ] II [ ] JJ [ ] KK [ ] LL [ ] MM [ ] NN [ X]
Field Status:	Required [ Y]
Field Definition:	United States Postal Service standard zip code.
Edit Rules/Criteria:	In PMR file, this field will contain spaces.

### 3.4.92 COS Code (PMR file only)

Characteristics:	ID [ OO - 5 ]      Type [ AN ]      Length [ 2 ]
Record Type:	AA [ ] BB [ ] CC [ ] DD [ ] EE [ ] FF [ ] GG [ ] HH [ ] II [ ] JJ [ ] KK [ ] LL [ ] MM [ ] NN [ ] OO [X]
Field Status:	Required [ Y ]
Field Definition:	Category of Service Code.
Edit Rules/Criteria:	In PMR file, this field will 2 digit Category of Service code.

### 3.4.93 COS Description (PMR file only)

Characteristics:	ID [ OO - 6 ]      Type [ AN ]      Length [ 41 ]
Record Type:	AA [ ] BB [ ] CC [ ] DD [ ] EE [ ] FF [ ] GG [ ] HH [ ] II [ ] JJ [ ] KK [ ] LL [ ] MM [ ] NN [ ] OO [X]
Field Status:	Required [ Y ]
Field Definition:	Description of Category of Service Code
Edit Rules/Criteria:	In PMR file, this field will have the description of the Category of Service code.

### 3.4.94 COS Begin Date (PMR file only)

Characteristics:	ID [ OO - 7 ]      Type [ N ]      Length [ 8 ]
Record Type:	AA [ ] BB [ ] CC [ ] DD [ ] EE [ ] FF [ ] GG [ ] HH [ ] II [ ] JJ [ ] KK [ ] LL [ ] MM [ ] NN [ ] OO [X]
Field Status:	Required [ Y ]
Field Definition:	Effective date of the Category of Service code.
Edit Rules/Criteria:	In PMR file, this field will have the effective date of the Category of Service code.

### 3.4.95 COS End Date (PMR file only)

Characteristics:	ID [ OO - 8 ]      Type [ N ]      Length [ 8 ]
Record Type:	AA [ ] BB [ ] CC [ ] DD [ ] EE [ ] FF [ ] GG [ ] HH [ ] II [ ] JJ [ ] KK [ ] LL [ ] MM [ ] NN [ ] OO [X]
Field Status:	Required [ Y ]
Field Definition:	End date of the Category of Service code. Default to 99999999 if blank.
Edit Rules/Criteria:	In PMR file, this field will have the end date of the Category of Service code.

### 3.5 Appendix 3E - Pharmacy Benefit Manager (PBM) File Layout

**File Header (T0)**

**One Per File**

Data Name	Picture	Actual Positions		Remarks	Sort Seq.
		From	To		
Filler	X(12)	01	12		
Date Created	X(05)	13	18	YYDDD (DDD=Julian Date)	
Filler	X(61)	19	78		
Record Type	X(02)	79	80	"T0"	

**Demographic (P1)**

**One Per Provider**

Data Name	Picture	Actual Positions		Remarks	Sort Seq.
		From	To		
Provider ID	X(06)	01	06		
Provider Name	X(25)	07	31		
Provider Type	X(02)	32	33		
NPI-IND	X(01)	34	34		
Provider 340B Indicator	X(01)	35	35		
Filler	X(43)	36	78		
Record Type	X(02)	79	80	"P1"	

**Provider Enrollment Status (P2)**

**One To Many Per Provider**

Data Name	Picture	Actual Positions		Remarks	Sort Seq.
		From	To		
Provider ID	X(06)	01	06	Active providers only.	1
Provider Status Type	X(01)	07	07	A = Active	
Provider Status	X(02)	08	09	01 = Active	
Begin Date	X(08)	10	17	YEARMMD	2
End Date	X(08)	18	25	YEARMMD	
Replacement Provider ID	X(06)	26	31		
Filler	X(47)	32	78		
Record Type	X(02)	79	80	"P2"	

Hawaii PMMIS  
Hawaii Prepaid Medical Management Information System  
Technical Guide - Provider

**License Data (P5) (Hawaii only)**

**One To Many**

Data Name	Picture	Actual Positions		Remarks	Sort Seq.
		From	To		
Provider ID	X(06)	01	06		
Agency ID	X(03)	07	09		
License ID	X(15)	10	24		
Certification Indicator	X(02)	25	26		
License Begin Date	X(08)	27	34	YEARMMDD	
License End Date	X(08)	35	42	YEARMMDD	
License Filler	X(36)	43	78		
Record Type	X(02)	79	80	"P5"	

**Specialty Data (P6)**

**One To Many**

Data Name	Picture	Actual Positions		Remarks	Sort Seq.
		From	To		
Provider ID	X(06)	01	06		
Specialty	X(03)	07	09		
Specialty Begin Date	X(08)	10	17	YEARMMDD	
Specialty End Date	X(08)	18	25	YEARMMDD	
License Filler	X(53)	26	78		
Record Type	X(02)	79	80	"P6"	

**Restriction (P8)**

**Zero To Many Per Provider**

Data Name	Picture	Actual Positions		Remarks	Sort Seq.
		From	To		
Provider ID	X(06)	01	06		
Service Type	X(01)	07	07	"B" = Bill Type "D" = ICD-9 Diag Code "H" = HCPCS Code "I" = ICD-10 Diag Code "P" = NDC "R" = Revenue code "X" = Unspecified	
Service From	X(11)	08	18	Service code	
Service To	X(11)	19	29	Service code	
Begin Date	X(08)	30	37	YEARMMDD	
End Date	X(08)	38	45	YEARMMDD	



Hawaii PMMIS  
Hawaii Prepaid Medical Management Information System  
Technical Guide - Provider

Data Name	Picture	Actual Positions		Remarks	Sort Seq.
		From	To		
Restriction Type	X(02)	46	47	"01" "02" "03" "04"  01 = Provider Prohibited-Fail Edit Condition 02 = Review Required-Fail Edit Condition 03 = PA Required-Fail Edit Condition 04 = Allowed Service-Bypass Provider Edits	
Agency ID	X(03)	48	50		
Group Type	X(05)	51	55		
Group ID	X(04)	56	59		
Proc Mod	X(02)	60	61		
Place of Service	X(02)	62	63		
Filler	X(15)	64	78		
Record Type	X(02)	79	80	"P8"	

**Alternate ID (S1)**

**Zero To Many**

Data Name	Picture	Actual Positions		Remarks	Sort Seq.
		From	To		
Provider ID	X(06)	01	06		
Alternate ID	X(15)	07	21		
Type	X(02)	22	23	'MM' = MMIS, 'NP' = NPI, 'MA' = Medicare Part A, 'MB' = Medicare Part B and 'MD' = Medicare	
Begin Date	X(08)	24	31	YEARMMD	
End Date	X(08)	32	39	YEARMMD	
Addr1 Filler	X(39)	40	78		
Record Type	X(02)	79	80	"S1"	

Hawaii PMMIS  
Hawaii Prepaid Medical Management Information System  
Technical Guide - Provider

**Address (R1) One To Many Per Provider**

Data Name	Picture	Actual Positions		Remarks	Sort Seq.
		From	To		
Provider ID	X(06)	01	06		
Address Type	X(01)	07	07	C = Correspondence Address P = Pay To Address S = Service Address	
Locator Code	X(02)	08	09		
Str-1	X(25)	10	34		
Str-2	X(25)	35	59		
Begin Date	X(08)	60	67	YEARMMD	
End Date	X(08)	68	75	YEARMMD	
Claims-Brand	X(02)	76	77	01=IHS, 02=Tribal, Spaces	
Addr1-Filler	X(01)	78	78		
Record Type	X(02)	79	80	"R1"	

**Address (R2) One To Many Per Provider**

Data Name	Picture	Actual Positions		Remarks	Sort Seq.
		From	To		
Provider ID	X(06)	01	06		1
Addr-Typ-2	X(01)	07	07	C = Correspondence Address P = Pay To Address S = Service Address	2
Loc-Code-2	X(02)	08	09		
Pay-Loc-Code	X(02)	10	11		
City	X(25)	12	36		
County	X(02)	37	38		
State	X(02)	39	40		
Zip	X(09)	41	49		
Country	X(02)	50	51	01 = USA 02 = Mexico 03 = Canada 99 = Other	
Business Phone	X(10)	52	61		
Emergency Phone	X(10)	62	71		
Addr2 Filler	X(07)	72	78		
Record Type	X(02)	79	80	"R2"	

**Address (R3) One To Many Per Provider**

Data Name	Picture	Actual Positions		Remarks	Sort Seq.
		From	To		
Provider ID	X(06)	01	06		
Addr-Typ-3	X(01)	07	07	C = Correspondence Address P = Pay To Address S = Service Address	
Loc-Code-3	X(02)	08	09		
Tax ID	X(20)	10	29		
Attn	X(25)	30	54		
Addr3-Filler	X(24)	55	78		
Record Type	X(02)	79	80	"R3"	

**File Trailer (T9) One Per File**

Data Name	Picture	Actual Positions		Remarks	Sort Seq.
		From	To		
Filler	X(12)	01	12		
Date Created	X(05)	13	17	YYDDD	
Total Records	9(13)	18	30		
Total Providers	9(06)	31	36		
Filler	X(42)	37	78		
Record Type	X(02)	79	80	"T9"	

### 3.6 Appendix 3F – Provider Type Definitions

#### 3.6.1 BC – Board Certified Behavior Analyst

A Board Certified Behavior Analyst (BCBA) is person who is licensed in the State and has a graduate-level certification in behavior analysis. BCBAs have Professionals who are certified at the BCBA level and are independent practitioners who provide behavior-analytic services. BCBAs supervise the work of Board Certified Assistant Behavior Analysts, Registered Behavior Technicians, and others who implement behavior-analytic interventions.

### 3.6.2 C1 – Acupuncturist

An acupuncturist is a person licensed by the State to perform ancient therapy for alleviation of pain, anesthesia and treatment of some diseases. Acupuncturists use long, fine needles inserted into specific points in order to treat painful conditions or produce anesthesia.

### 3.6.3 C2 – Federally Qualified Health Center (FQHC)

A health clinic that qualifies under the provisions of Sections 329, 330, or 340 of the Public Health Service Act

### 3.6.4 C3 – Family Planning Services

Provides reproductive counseling services.

### 3.6.5 D1 – Dentist – Endodontist

### 3.6.6 D2 – Dentist – Pedodontist

### 3.6.7 D3 – Dentist – Oral Surgeon

### 3.6.8 D4 – Clinic – Dental Services

A State-licensed facility that is not hospital-based where dental services are provided at a fixed specific location.

### 3.6.9 01-Group Billing Provider

A provider that provides billing services or acts as a billing agent to one or more providers but delivers no direct services to a patient. Group Billing providers may only be used as a billing provider on an encounter. Group Billing providers may not be used as a servicing, attending, prescribing, or referring provider. FOR MQD USE ONLY.

### 3.6.10 Z1-Out-Of-State Middle-Risk Managed Care Only

One of the following types of providers whose primary service location is NOT in Hawaii: Physician, Non-physician practitioners, Medical groups/clinics (except for physical therapy groups), Ambulatory surgery centers, End-state renal disease centers, FQHCs & RHCs, Hospitals, Mammography screening centers, Pharmacies, Radiation therapy centers, Skilled nursing facilities. These providers need to be licensed in the service location state, and properly enrolled and screened, by the health plan.

### 3.6.11 02-Hospital

A hospital is an institution whose primary function is to provide inpatient diagnostic and therapeutic services for a variety of medical conditions, both surgical and non-surgical, to a wide population group. The hospital treats patients in an acute phase of illness or injury, characterized by a single episode or a fairly short duration, from which the patient returns to his or her normal or previous level of activity.

### 3.6.12 03-Pharmacy

### 3.6.13 04-Laboratory

Any facility that examines materials from the human body for purposes of providing information for the diagnosis, prevention, or treatment of any disease or impairment of, or the assessment of, the health of human beings. Typical divisions of a clinical laboratory include hematology, cytology, bacteriology, histology, biochemistry, medical toxicology, and serology.

### 3.6.14 05-Clinic

A facility or distinct part of one used for the diagnosis and treatment of outpatients. "Clinic" is irregularly defined, either including or excluding physician's offices and allied health professionals, sometimes being limited to organizations serving specialized treatment requirements or distinct patient/client groups (e.g., radiology, public health).

### 3.6.15 06-Emergency Transportation

An emergency vehicle used for transporting patients to a health care facility. Includes basic and advanced life support.

### 3.6.16 07-Dentist

A dentist is a person qualified by a doctorate in dental surgery (DDS) or dental medicine (DMD). Licensed by the state to practice dentistry and practicing within the scope of that license. Many dentists are general practitioners who handle a wide variety of dental needs. Other dentist's practice in one of eight specialty areas recognized by the American Dental Association maxillofacial surgery, orthodontics, periodontics, prosthodontics, public health, oral pathology and pediatric dentistry.

### 3.6.17 08-MD-Physician

A physician is a person qualified by a doctorate in medicine (M.D.), licensed by the state, and practicing within the scope of that license. A physician generally has primary responsibility for the health care of the patient. M.D.s may use all accepted methods of treatment, including drugs and surgery.

### 3.6.18 09-Certified Nurse Midwife

An individual educated in the two disciplines of nursing and midwifery, who possesses evidence of certification according to the requirements of the American College of Nurse-Midwives and licensed by the state to perform services within the scope of that license.

### 3.6.19 10-Podiatrist

A podiatrist is a person qualified by a Doctor of Podiatric Medicine (D.P.M.) degree, licensed by the state, and practicing within the scope of that license. Podiatrists diagnose and treat foot diseases and deformities. They perform medical, surgical and other operative procedures, prescribe corrective devices and prescribe and administer drugs and physical therapy.

### 3.6.20 11-Psychologist

An individual, who specializes in psychological research, testing, and/or therapy, licensed by the State. Psychology is the branch of science that deals with mental processes and behavior, composed of the following major fields: abnormal, clinical, comparative, counseling, developmental, educational, engineering, experimental, industrial, learning, motivation, perception, personality, physiological, psychometrics, school, and social psychology.

### 3.6.21 12-Certified Registered Nurse Anesthetist

(1) A licensed registered nurse with advanced specialty education in anesthesia who, in collaboration with appropriate health care professionals, provides preoperative, intraoperative, and postoperative care to patients and assists in management and resuscitation of critical patients in intensive care, coronary care, and emergency situations. Nurse anesthetists are certified following successful completion of credentials and state licensure review and a national examination directed by the Council on Certification of Nurse Anesthetists.

(2) A registered nurse who is qualified by special training to administer anesthesia in collaboration with a physician or dentist and who can assist in the care of patients who are in critical condition.

### 3.6.22 13-Occupational Therapist

An occupational therapist is a person qualified by completion of an approved program in occupational therapy, licensed by the state and practicing within the scope of that license, or where licensure does not exist, certified by the American Occupational Therapy Certification Board. An occupational therapist evaluates the self-care, work and leisure performance skills of well and disabled clients and plans and implements programs to restore, develop or maintain the task performance skills necessary for daily living and for the client's particular occupational role.

### 3.6.23 14-Physical Therapist

A physical therapist is a person qualified by an accredited program in physical therapy, licensed by the state, and practicing within the scope of that license. Physical therapists treat disease, injury, or loss of a bodily part by physical means, such as the application of light, heat, cold, water, electricity, massage and exercise. They develop treatment plans based upon each patient's strengths, weaknesses, and range of motion and ability to function.

### 3.6.24 15- Speech/Hearing Therapist

A speech/hearing therapist a person qualified by a master's degree in speech-language pathology, and where applicable, licensed by the state and practicing within the scope of the license. Also, known as speech pathologist, a speech therapist evaluates patients with language and speech impairments or disorders, whether arising from physiological and neurological disturbances, defective articulation or foreign dialects, and conducts remedial programs designed to restore or improve their communication efficacy. Speech pathologists assess and treat persons with speech, language, voice, and fluency disorders.

### 3.6.25 16-Chiropractor

A provider qualified by a Doctor of Chiropractic (D.C.), licensed by the State and who practices chiropractic medicine -that discipline within the healing arts which deals with the nervous system and its relationship to the spinal column and its interrelationship with other body systems.

### 3.6.26 17-Naturopath

An individual licensed by the State to practice naturopathy, a system of therapeutics in which neither surgical nor medicinal agents are used, dependence being placed only on natural (non-medicinal) forces.

### 3.6.27 18-Physician Assistant

A physician assistant is a person who has successfully completed an accredited education program for physician assistant, is licensed by the state and is practicing within the scope of that license. Physician assistants are formally trained to perform many of the routine, time-consuming tasks a physician can do. In some states, they may prescribe medications. They take medical histories, perform physical exams, order lab tests and x-rays, and give inoculations. Most states require that they work under the supervision of a physician.

#### 19-Registered Nurse Practitioner

(1) A registered nurse provider with a graduate degree in nursing prepared for advanced practice involving independent and interdependent decision making and direct accountability for clinical judgment across the health care continuum or in a certified specialty.

(2) A registered nurse who has completed additional training beyond basic nursing education and who provides primary health care services in accordance with state nurse practice laws or statutes. Tasks performed by nurse practitioners vary with practice requirements mandated by geographic, political, economic, and social factors. Nurse practitioner specialists include, but are not limited to, family nurse practitioners, gerontological nurse practitioners, pediatric nurse practitioners, obstetric-gynecologic nurse practitioners, and school nurse practitioners.



### 3.6.28 20-Respiratory Therapist

A respiratory therapist is a person who has graduated from a respiratory therapy program accredited by the Committee on Allied Health Education and Accreditation, and where applicable, is licensed by the state and is practicing within the scope of that license. A respiratory therapist administers oxygen and other gases and provides assistance with equipment to patients with either acute or chronic breathing difficulties, often within the home.

### 3.6.29 21-Massage Therapist

An individual trained in the manipulation of tissues (as by rubbing, stroking, kneading, or tapping) with the hand or an instrument for remedial or hygienic purposes.

### 3.6.30 22-Nursing Home

(1) Is primarily engaged in providing to residents- (A) skilled nursing care and related services for residents who require medical or nursing care, (B) rehabilitation services for the rehabilitation of injured, disabled, or sick persons, or, on a regular basis, health-related care and services to individuals who because of their mental or physical condition require care and services (above the level of room and board) which can be made available to them only through institutional facilities, and is not primarily for the care and treatment of mental diseases;

(2) has in effect a transfer agreement with one or more hospitals.

### 3.6.31 23-Home Health Agency

A non-facility provider that renders outpatient outreach services that are not provided at a specific location. The licensure or registration is assigned to the agency rather than to the individual practitioners as would be the case in a group practice.

### 3.6.32 24-Personal Care Attendant

Only QExA health plans may use this provider type.

### 3.6.33 25-Developmentally Disabled Group Home

Health plans may not use this provider type

### 3.6.34 27-Adult Day Health

Only QExA health plans may use this provider type.

### 3.6.35 28-Non-emergency Transportation

A commercial vehicle (taxi, medical van) used for the transporting of persons in non-emergency situations to and from medically necessary services. The vehicle meets local, county or state regulations set forth by the jurisdictions where it is located.

### 3.6.36 29-Community/Rural Health Center

A health clinic that qualifies under the provisions of Sections 329, 330, or 340 of the Public Health Service Act

### 3.6.37 30-Durable Medical Equipment & Medical Supplies

A supplier of medical equipment such as respirators, wheelchairs, home dialysis systems, or monitoring systems, that are prescribed by a physician for a patient's use in the home and that are usable for an extended period of time.

### 3.6.38 31-Osteopath

A physician is a person qualified by a doctorate in osteopathy (D.O.), licensed by the state, and practicing within the scope of that license. A physician generally has primary responsibility for the health care of the patient. While D.O.s may use all accepted methods of treatment, including drugs and surgery, D.O.s place special emphasis on the body's musculoskeletal systems.

### 3.6.39 32-Medical Foods

Health plans may not use this provider type

### 3.6.40 33-Rehabilitation Center

A hospital or facility that provides health-related, social and/or vocational services to disabled persons to help them attain their maximum functional capacity.

### 3.6.41 34-Case Management Services

### 3.6.42 35-Hospice

A provider organization, or distinct part of the organization, which renders an interdisciplinary program providing palliative care, chiefly medical relief of pain and supporting services, which addresses the emotional, social, financial, and legal needs of terminally ill patients and their families where an institutional care environment is required for the patient.

### 3.6.43 36-Assisted Living Home/HCBS

Assisted Living Home/Home & Community Based Services.

### 3.6.44 37-Homemaker

Health plans may not use this provider type.

### 3.6.45 38-Developmentally Disabled Day Care

Health plans may not use this provider type.

### 3.6.46 39-Habilitation Provider

Health plans may not use this provider type.

### 3.6.47 40-Attendant Care

Health plans may not use this provider type.

### 3.6.48 41-Dialysis Clinic

A State-licensed, non-hospital-based facility that provides renal dialysis services at a fixed specific location. An ambulatory dialysis facility does not provide overnight accommodations.

### 3.6.49 42-Hospital Affiliated Clinic

### 3.6.50 43-Ambulatory Surgical Center

A State-licensed, non-hospital-based facility that provides outpatient surgical procedures at a fixed specific location. An ambulatory surgical facility does not provide overnight accommodations.

### 3.6.51 44-Environmental (LTC)

Environmental providers remodel homes when it is cost effective alternative to nursing facility placement.

### 3.6.52 46-Nurse (Private – RN/LPN)

Only QExA health plans may use this provider type.

### 3.6.53 47-Registered Dietician

A dietitian (or dietician) is an expert in food and nutrition and who has met academic and professional requirements. A dietitian alters their patient's nutrition based upon their medical condition and individual needs. Dietitians are regulated healthcare professionals licensed in the state to assess, diagnose, and treat nutritional problems. Dietitians have to complete continuing professional educational requirements to maintain registration on an ongoing basis.

### 3.6.54 48-Nutritionist

Health plans may not use this provider type.

### 3.6.55 49-Assisted Living Center

These centers are composed of individual apartments that provide room, board and general supervision, as well as coordinate supportive living services on a 24-hour basis.

### 3.6.56 50-Adult Foster Care

Only QExA health plans may use this provider type.

### 3.6.57 51-Behavioral Health Counselor

A provider who is trained and educated in the performance of behavior health services through interpersonal communications and analysis. Training and education at the specialty level usually requires a master's degree and clinical experience and supervision for licensure or certification.

### 3.6.58 52-Mental Health Clinic

### 3.6.59 53-Supervisory Care Home

Supervisory care homes provide room, board, and general supervision to more than five people.

### 3.6.60 54-Dental Hygienist

A preventive health professional who has graduated from an accredited dental hygiene program in an institution of higher education, licensed in dental hygiene, who provides educational, clinical, research, administrative, and therapeutic services supporting total health through the promotion of optimal oral health.

### 3.6.61 55-Hotels

### 3.6.62 56-Boarding Homes

A boarding home provides care, respite care, and homemaker services.

### 3.6.63 57- Residential Treatment Center

A residential treatment center (RTC) is a facility or distinct part of a facility that provides, to children and adolescents, a total, twenty-four hour, therapeutically planned group living and learning situation where distinct and individualized psychotherapeutic interventions can take place. Residential treatment is a specific level of care to differentiated from acute, intermediate, and long-term hospital care, when the least restrictive environment is maintained to allow for normalization of the patient's surroundings. The RTC must be both physically and programmatically distinct if it is a part or sub-unit of a larger treatment program. A RTC is organized and professionally staffed to provide residential treatment of mental disorders to children and adolescents who have sufficient intellectual potential to respond to active treatment (that is, for whom it can reasonably be assumed that treatment of the mental disorder will result in an improved ability to function outside the RTC) for whom outpatient treatment, partial hospitalization or protected and structured environment is medically or psychologically necessary.

### 3.6.64 58-School for the Deaf and Blind

Provider Type reserved for the Hawaii School for the Deaf and Blind.

### 3.6.65 59-Dental Laboratory

A commercial laboratory specializing in the construction of dental appliances that conform to a dentist's specifications including the construction of dentures (complete or partial), orthodontic appliances, bridgework, crowns, and inlays.

### 3.6.66 60-Blood Bank

An institution (organization or distinct part thereof) that performs, or is responsible for the performance of, the collection, processing, storage and/or issuance of human blood and blood components, intended for transfusion. The institution may also collect, process, and/or distribute human tissue, including bone marrow and peripheral blood progenitor cells, intended for transplantation.

### 3.6.67 61-Eye Bank

An eye bank procures and distributes eyes for transplant, education and research. To promote patient safety, donated eyes and donor medical histories are evaluated based on strict Eye Bank Association of America Medical Standards

### 3.6.68 62-Audiologist

An audiologist is a person qualified by a master's degree in Audiology, licensed by the state, where applicable, and practicing within the scope of that license. Audiologists evaluate and treat patients with impaired hearing. They plan, direct and conduct rehabilitative programs with auditory substitution devices (hearing aids) and other therapy.

### 3.6.69 63-Drug and Alcohol Rehab

Provides drug and rehabilitation services to acute members.

### 3.6.70 64-Detox Center

LARC

### 3.6.71 65-Hospital Outpatient Surgical Center

A State-licensed, hospital-based facility that provides outpatient surgical procedures at a fixed specific location. An outpatient surgical facility does not provide overnight accommodations.

### 3.6.72 66-Organ Bank

A federally designated organization that works with hospital personnel in retrieval of organs for transplantation. The federal government designates an OPO's service area and the hospitals with which an OPO is to establish working relationships.

### 3.6.73 67-Perfusionist

Operates the perfusionist machine that provides oxygenated blood during open-heart surgery or lung surgery.

### 3.6.74 68-Homeopath

A provider who is educated and trained in a system of therapeutics in which diseases are treated by drugs which are capable of producing in healthy persons symptoms like those of the disease to be treated. Treatment requires administering a drug in minute doses.

### 3.6.75 69-Optometrist

An optometrist is a person qualified by a Doctor of Optometry (O.D.) degree, licensed by the state and practicing within the scope of that license. Optometrists examine the eyes and related structures to determine the presence of any abnormality and prescribe and adapt lenses or optical aids. They use drugs for diagnosis in all states and for treatment in some states. They do not perform surgery.

### 3.6.76 70-Home Delivered Meals

Only QExA health plans may use this provider type.

### 3.6.77 71-Psychiatric Hospital

An organization including a physical plant and personnel that provides multidisciplinary diagnostic and treatment mental health services to patients requiring the safety, security, and shelter of the inpatient or partial hospitalization settings.

### 3.6.78 73-Default Provider

For MQD use only.

### 3.6.79 74-Alternative Residential Facility

A facility which provides room, board, and specialized outpatient counseling.

### 3.6.80 75-MHS Social Worker

A clinical social worker is a person who is qualified by a master of Social Work (M.S.W.) degree, licensed, certified or registered by the state as a social worker and practicing within the scope of that license. A social worker provides assistance and counseling to patients and their families and dealing with social, emotional and environmental problems.

### 3.6.81 77-Mental Health Rehabilitation

Mental health rehabilitation provides outpatient mental health and psychiatric counseling

### 3.6.82 78-Mental Health Residential Treatment Center

Provides room, board, and inpatient counseling.

### 3.6.83 79-Vision Center

Broad category grouping individuals who renders services related to the human eye and visual systems, but are not an allopathic or osteopathic physicians.

### 3.6.84 82-Surgical First Assistant

Licensed nurse or physician's assistant that assists the surgeon in the operating room and must be supervised by a licensed physician surgeon.

### 3.6.85 83-Free Standing Birthing Center

A State-licensed facility that is not hospital-based where services are provided at a fixed specific location. An ambulatory care facility does not provide overnight accommodations.

### 3.6.86 84-Licensed Midwife

A State-license person qualified to provide obstetric and neo-natal care in the management of women having normal pregnancy, labor and childbirth. The lay midwife is licensed in some states.



### 3.6.87 86 – Certified Marriage/Family Therapist (CMFT)

A State-licensed person who uses the title of marriage and family therapist and practices marriage and family therapy. Marriage and family therapy practice means the application of psychotherapeutic and family systems theories and techniques in the delivery of services to individuals, couples, or families in order to diagnose and treat mental, emotional, and nervous disorder, whether these are behavioral, cognitive or affective, within the context of the individual’s relationship.

### 3.6.88 90-QMB Only Provider

Only QExA health plans may use this provider type.

### 3.6.89 95-Interpreter Services

Only QExA health plans may use this provider type.

## 3.7 Appendix 3G – Provider Types and Licensing

This table represents those provider types that require a license in order to be active within HPMMIS. This is not a complete list of licenses that are associated with a provider type. This list represents the minimum requirement for activating providers with each provider type.

<b>Provider Type</b>	<b>Licensing Agency</b>	<b>License Type</b>
BC-Board Certified Behavior Analyst	060 – Board of Behavior Analyst	BA-Behavior Analyst
C1-Acupuncturist	020-Board of Acupuncture	ACU-Acupuncturist
D1-Dentist – Endodontist	220-Board of Dental Examiners	DT-Dentist
D2-Dentist - Pedodontist	220-Board of Dental Examiners	DT-Dentist
D3-Dentist – Oral Surgeon	220-Board of Dental Examiners	DT-Dentist
D4-Clinic – Dental Services	220-Board of Dental Examiners	DT-Dentist
03-Pharmacy	820-Board of Pharmacy	PH-Pharmacist PHY-Pharmacy
07-Dentist	220-Board of Dental Examiners	DT-Dentist
08-Physician	630-Board of Medical	MD-Physician

Hawaii PMMIS  
Hawaii Prepaid Medical Management Information System  
Technical Guide - Provider

<b>Provider Type</b>	<b>Licensing Agency</b>	<b>License Type</b>
	Examiners	
09-Certified Nurse Midwife	750-Board of Nursing	RN-Registered Nurse APRN-Advanced Practice Registered Nurse
10-Podiatrist	630-Board of Medical Examiners	PO-Podiatrist
11-Psychologist	860-Board of Psychology	PSY-Psychologist
12-Certified Registered Nurse Anesthetist	750-Board of Nursing	RN-Registered Nurse APRN-Advanced Practice Registered Nurse
13-Occupational Therapist	770-Occupational Therapy Program	OT-Occupational Therapist
14-Physical Therapist	825-Board of Physical Therapy	PT-Physical Therapist
15-Speech/Hearing Therapist	930-Board of Speech Pathology and Audiology	SP-Speech Pathologist
16-Chiropractor	130-Board of Chiropractic Examiners	DC-Chiropractor
17-Naturopath	720-Board of Examiners in Naturopathy	ND-Naturopath
18-Physician's Assistant	630-Board of Medical Examiners	AMD-Physician's Assistant
19-Registered Nurse Practitioner	750-Board of Nursing	RN-Registered Nurse APRN-Advanced Practice Registered Nurse
21-Massage Therapist	620-Board of Massage Therapy	MAT-Massage Therapist
31-Osteopath	630-Board of Medical Examiners	DOS-Osteopath
50-Adult Foster Care	056-Certification/License Foster Home	HCBS-Home & Community- Based Services
51- Behavioral Health Counselor	640-Mental Health Counselor	MHC-Mental Health Counselor
54-Dental Hygienist	220-Board of Dental Examiners	DH-Dental Hygienist
62-Audiologist	930-Board of Speech Pathology and Audiology	AUD-Audiologist
68-Homeopathic	720-Board of Examiners in Naturopathy	ND-Naturopath
69-Optometrist	780-Board of Examiners in Optometry	OD-Optometrist
75-MHS Social Worker	920-Social Worker Program	LSW-Licensed Social Worker
79-Vision Center	230-Dispensing Opticians	DIO-Dispensing Optician

Hawaii PMMIS  
Hawaii Prepaid Medical Management Information System  
Technical Guide - Provider

<b>Provider Type</b>	<b>Licensing Agency</b>	<b>License Type</b>
	Program	
86-Certified Marriage/Family Therapist (CMFT)	560-Marriage & Family Therapists Program	MFT-Marriage & Family Therapist

### 3.8 Appendix 3H – State and Territory Code Table

<b>Code</b>	<b>Description</b>
AK	Alaska
AL	Alabama
AR	Arkansas
AZ	Arizona
CA	California
CO	Colorado
CT	Connecticut
DC	District of Columbia
DE	Delaware
FL	Florida
GA	Georgia
GU	Guam
HI	Hawaii
IA	Iowa
ID	Idaho
IL	Illinois
IN	Indiana
KS	Kansas
KY	Kentucky
LA	Louisiana
MA	Massachusetts
MD	Maryland
ME	Maine
MI	Michigan
MN	Minnesota
MO	Missouri
MS	Mississippi
MT	Montana
NC	North Carolina
ND	North Dakota

**Hawaii PMMIS**  
**Hawaii Prepaid Medical Management Information System**  
**Technical Guide - Provider**

<b>Code</b>	<b>Description</b>
NE	Nebraska
NH	New Hampshire
NJ	New Jersey
NM	New Mexico
NV	Nevada
NY	New York
OH	Ohio
OK	Oklahoma
OR	Oregon
PA	Pennsylvania
PR	Puerto Rico
RI	Rhode Island
SC	South Carolina
SD	South Dakota
TN	Tennessee
TX	Texas
UT	Utah
VA	Virginia
VT	Vermont
WA	Washington
WI	Wisconsin
WV	West Virginia
WY	Wyoming

### 3.9 Appendix 3I – Med-Quest/Health Plans File Transfers

#### 3.9.1 Overview

The SFTS (Secure File Transfer Server) is the source of all file transfers between the MQD and the health plans. The SFTS accepts a standard web browser via Hypertext Transfer Protocol over Secure Socket Layer (HTTPS) and File Transfer Protocol (FTP) over Secure Shell (SSH) SFTP.

#### 3.9.2 Availability

The SFTS is available 24 hours a day, seven days a week. Information on when provider files should be submitted is available in this manual. Please refer to the appropriate section.

#### 3.9.3 Logon

An Electronic Data Request form along with instructions will be made available to Health Plans in order to receive access to the SFTS. A health plan can request for a

service account which is used for automated processes as well as individual logon access. Please email our Helpdesk at [mqdhelpdesk@dhs.hawaii.gov](mailto:mqdhelpdesk@dhs.hawaii.gov) to request for access. There will no longer be a generic logon account for each health plan.

### 3.9.4 Filenames

Filenames will follow the 8.3 standard with alphanumeric characters, except for the provider and encounter filenames, which will utilize a 10.3 format. Each health plan has been assigned a two-character health plan identifier for the purpose of naming files.

The plan identifiers are:

Aloha Care – non-ABD clients	AM
Aloha Care – ABD clients	XA
HMSA – non-ABD clients	HM
HMSA – ABD clients	XH
Kaiser – non-ABD clients	KM
Kaiser – ABD clients	XK
Med-QUEST Division Files (Provider Master Registry)	MQ
Ohana (Wellcare) – ABD clients	XO
Ohana (Wellcare) – non-ABD clients	HQ
United Health Care – non-ABD clients	IQ
United Health Care (formerly Evercare) – ABD clients	XU
Ohana (Wellcare) Behavioral Health	OB

### 3.9.5 Provider Filenames

Files will be sent and received by health plans using the naming conventions listed in the table below. Provider filenames will use a 10.3 format where characters 1-2 identify the health plan; characters 3-6 identify the year; characters 7-8 identify the month; and characters 9-10 identify the day that the submission is due to the MQD SFTS. The three character extensions to these files are listed in a separate table below depending on the type of provider file.

Submissions>Returns	Filename	Extension
Health Plan Provider Network (monthly plan submittal)	XXYYYYMMDD	.HPS
Health Plan Provider Monthly Error Report	XXYYYYMMDD	.HPQ
Provider Master Registry	XXYYYYMMDD	.PMR

### 3.9.6 Directory Structure

The directory structure for the SFTP (SFTS) is in the diagram below.

**HI SFTP (Secure FTP) Directory Structure**  
<https://sftp.statemedicaid.us/HI/>

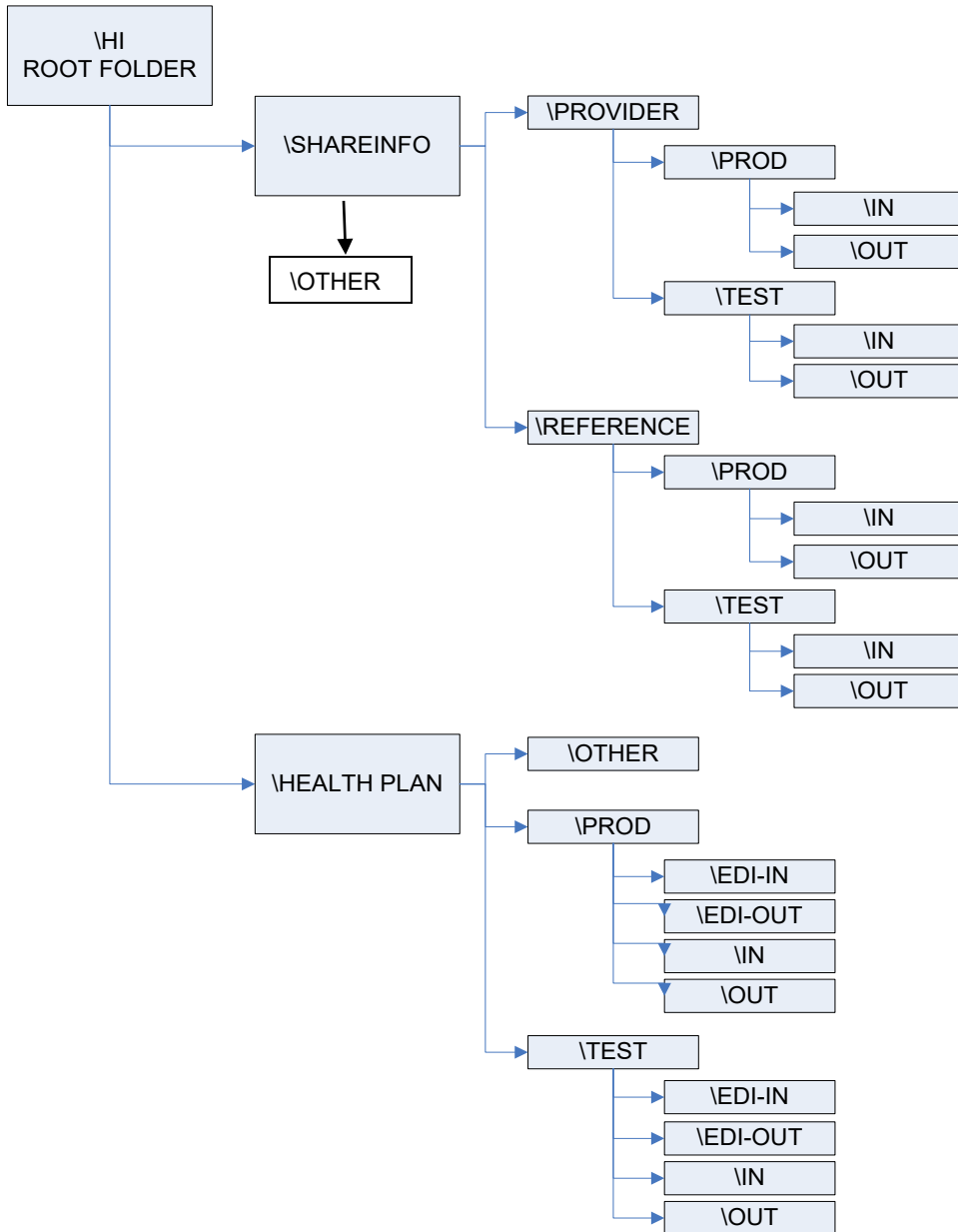

Last mod: 03/27/2012

### 3.9.7 Prod Folder

Production provider files should be placed in the IN subfolder. All output files will be placed in the OUT subfolder.

### 3.9.8 Test Folder

The Test folder will be used for testing changes that the MQD or health plan may need. Health plans submitting test provider files should place them in the IN sub folder. The output files will be placed in the OUT sub folder.

### 3.9.9 Other Folder

The OTHER folder will be used to transmit miscellaneous files or reports between MQD and health plans.

### 3.9.10 Share Info Folder

Files which do not contain HIPAA data and can be shared with all health plans will be placed under this folder. The PMR file will be placed in the Provider/Prod/Out subfolder.

## 3.10 Appendix 3J – Health Plan IDs

<b>Plan Code</b>	<b>Description (ABD = Aged, Blind or Disabled)</b>
ALOHAC	Aloha Care – non-ABD clients
XALOHA	Aloha Care – ABD clients
HMSAAA	HMSA – non-ABD clients
XHMSAA	HMSA – ABD clients
KAISER	Kaiser - non-ABD clients
XKAISR	Kaiser – ABD clients
XOHANA	Ohana (Wellcare) – ABD clients
OHANAA	Ohana (Wellcare) - non-ABD clients
OHANBH	Ohana (Wellcare) – Behavioral Health
UNITED	United Health Care – non-ABD clients
XUNITD	United Health Care – ABD clients

## 4 Contacts

### 4.1 Systems Office

System	Primary
All Systems	MQD Help Desk 808-900-6020
Encounter	Wileen Ortega 808-900-6024
Provider, SFTP password reset	Wileen Ortega 808-900-6024
834 Rosters, Recipient (Health Plan members), DMO website, SFTP password reset	Haidee Shaw 808-692-7963

**To report problems, please send an email to [mqdhelpdesk@dhs.hawaii.gov](mailto:mqdhelpdesk@dhs.hawaii.gov).**

**If your problem is critical to your operation, please call the above personnel.**

For calls reaching Systems Office Staff voicemail, a customer can leave a message or press “03” and the call will be transferred to the MQD Help Desk for assignment. If you get the Help Desk voicemail, please leave a message and a SO staff member will return your call within 2 hours **(during normal business hours)**.



## 5 Addendums to the Provider Technical Guide

<Page Intentionally Left Blank>